

A FREE RESOURCE PACK FROM EDUCATIONCITY

Sample Weekly Lesson Plan



Literacy



Mathematics



Science



Computing

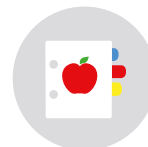

Lesson Plans



Suitability

Sample Weekly Lesson Plan

What Does This Pack Include?

This pack has been created by teachers, for teachers. In it, you'll find a sample weekly Lesson Plan, covering all seven areas of learning, along with teacher resources, Activity Sheets and Answer Sheets relating to the content.

7 AREAS OF LEARNING WEEKLY LESSON PLAN

EMOTIONAL ROLLERCOASTER

Learning Objective: People and communities

Know that other children don't always enjoy the same things, and are sensitive to this.

- Activity Sheet
- Activity Sheet with Answers

BE A BUG

Learning Objective: Understanding

Follow instructions involving several ideas or actions.

- Activity Sheet

GRUMPY GOATS FROM LETTERS AND SOUNDS

Learning Objective: Reading

Use phonic knowledge to decode regular words and read them aloud accurately.

- Activity Sheet
- Activity Sheet with Answers

OLLIE OCTOPUS FROM LETTERS AND SOUNDS

Learning Objective: Reading

Use phonic knowledge to decode regular words and read them aloud accurately.

- Activity Sheet
- Activity Sheet with Answers

CURLY CATERPILLAR FROM LETTERS AND SOUNDS

Learning Objective: Reading

Use phonic knowledge to decode regular words and read them aloud accurately.

- Activity Sheet
- Activity Sheet with Answers

KIT KITE FROM LETTERS AND SOUNDS

Learning Objective: Reading

Use phonic knowledge to decode regular words and read them aloud accurately.

- Activity Sheet
- Activity Sheet with Answers

GOING SPARE

Learning Objective: Reading

Use phonic knowledge to decode regular words and read them aloud accurately.

- Activity Sheet
- Activity Sheet with Answers

Continued

Sample Weekly Lesson Plan (Continued)

ABC...

Learning Objective: Reading

Use phonic knowledge to decode regular words and read them aloud accurately.

- Activity Sheet

BALLOON RIDE

Learning Objective: Reading

Use phonic knowledge to decode regular words and read them aloud accurately.

- Activity Sheet
- Activity Sheet with Answers

COUNTING BUGS

Learning Objective: Numbers

Count reliably with numbers from 1 to 20.

- Activity Sheet
- Activity Sheet with Answers

TRACTOR RACE

Learning Objective: Numbers

Place the numbers 1 to 20 in order and say which number is one more or one less than a given number.

- Activity Sheet
- Activity Sheet with Answers

EGGS FOR BREAKFAST

Learning Objective: Numbers

Count reliably with numbers from 1 to 20.

- Activity Sheet
- Activity Sheet with Answers

MAKE A WRISTBAND

Learning Objective: Understanding

Follow instructions involving several ideas or actions.

- Activity Sheet

NUMBER FLASH CARDS

NUMBER FORMATION

ALPHABET FLASH CARDS



LETTER FORMATION

PRACTICE WORDS

Sample Weekly Lesson Plan (Continued)

Other Resources Linking to the Theme

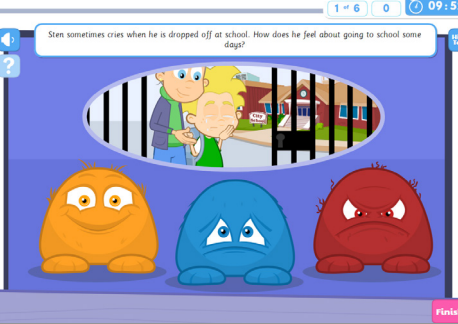
Before finalising what to include in your lessons, check out the Computing content on EducationCity itself too. It's simple to find, just enter the Content ID or name into EducationCity's Search tool! We've included a selection here but others are mentioned in the Termly Lesson Plan too.

Activities: Educational Content	Topic Tools: Explore Concepts as a Class	Learn Screens: Introduce or Reinforce a New Concept
Moody Monsters Content ID: 26076	Counting Content ID: 1889	Meet an Alien Content ID: 12590
		
Identify if a character is feeling happy, sad or cross and recognise that not everyone reacts in the same way in similar situations.	Count up to 20 with your students using our interactive Topic Tool, which generates random numbers of objects for your students to count.	Explore and practise CVC words with the /o/ sound with your students with our interactive Learn Screen.

Enjoyed these resources?

Why not start a free trial of the full EducationCity resource and see what else we can offer you?

Email us at trials@educationcity.com
or call us on +44 (0)1572 725080!

EYFS 7 Areas of Learning: Weekly Summary



Week beginning: _____

AREA	SUB AREAS COVERED	ADULT-LED ACTIVITIES	CONTINUOUS PROVISION: INDOOR/OUTDOOR
Personal, Social & Emotional Development	<p>Making Relationships</p> <p>Self Confidence & Self Awareness</p> <p>Managing Feelings & Behaviour</p>	<p>Group Activity</p> <ul style="list-style-type: none"> Moody Monsters Activity – children to discuss what makes them happy, sad and cross. Compare to other children in the group. Emotional Rollercoaster Activity - discuss feelings and emotions of characters and in group What can we do if we are sad or cross to be happy again? What could you do if another group member was sad or cross? <p>Link vocabulary – English.</p>	<p>Small Group or Independent</p> <ul style="list-style-type: none"> Emotional Rollercoaster Activity Sheet - children to draw things that make them feel each stated emotion Share activity in play area - encourage sharing, taking turns and inclusion
Communication & Language	<p>Listening & Attention</p> <p>Understanding</p> <p>Speaking</p>	<p>Whole Class</p> <ul style="list-style-type: none"> Make a Wristband Activity: Listening to and understanding instructions. Links to identifying colours & shapes (Maths) <p>Group Activity</p> <ul style="list-style-type: none"> Be a Bug Activity: LA - Which bug would you be. Why? U - Where would you go? Why? S - Talk about where you might go and why? What noises does that bug make? 	<p>Independent/1:1 (AFL Opportunities)</p> <ul style="list-style-type: none"> Be a Bug Activity Sheet: AFL: 1-1 Why? Reasoning Dig the Garden Activity - children to listen to question, pay attention to pictures, understand question and repeat names of objects. Garden Bugs Activity: responding to a story Indoor activities: on game, printed worksheet to be used for 1:1 AFL. Reading links.
Physical Development	<p>Moving & Handling</p> <p>Health & Self Care</p>	<p>Whole Class</p> <p>M&H: Clap Your Hands Sing-Along Video - children copy actions of Stig, Klara and animals. Links - following instructions - listening and understanding.</p> <p>Group Activity</p> <ul style="list-style-type: none"> Food and Glory Activity: identifying healthy foods <p>Additional Resources</p> <ul style="list-style-type: none"> Going to Sea Video - children can create actions for repeated words - encourages use of /ee/ sound also 	<p>Independent/ 1:1 (AFL Opportunities)</p> <ul style="list-style-type: none"> Indoor activities: Weed Attack Activity: developing hand-eye coordination and mouse control in early computing skills. Outdoor activities: skipping ropes, hopscotch, hula-hoops (encourage use of sharing PSED) <p>Small Group</p> <ul style="list-style-type: none"> In relation to group 'identifying healthy foods activity', children to try new fruits and vegetables
Understanding of the World (Science Focus: Bugs and Plants)	<p>People & Communications</p> <p>The World</p> <p>Technology</p>	<p>PSED and CL links for communications</p> <p>Use of EducationCity site for computer technology</p> <ul style="list-style-type: none"> Days of the Week Video each morning for children to identify which day it is 	<ul style="list-style-type: none"> Animal Bedtime Activity: where do animals sleep? Leap Frog Activity – life cycle of a frog activity 'Where do animals live?' jigsaw puzzles (encourage pair/small groups to complete jigsaws)

EYFS 7 Areas of Learning: Weekly Summary



Week beginning: _____

AREA	SUB AREAS COVERED	ADULT-LED ACTIVITIES	CONTINUOUS PROVISION: INDOOR/OUTDOOR
Literacy	Reading and Writing (Incl. phonics)	<p>Class Activity</p> <ul style="list-style-type: none"> • ABC... Sing-Along Video: familiarise children with letter names in addition to each phoneme • Letters and Sounds Activities focusing on g, o, c, k sounds • /o/ phoneme focus = Meet an Alien Learn Screen <p>Group Activity(ies)</p> <ul style="list-style-type: none"> • /o/ phoneme focus = Meet an Alien Activity. Children use sound buttons to segment and blend. HAPS to try and write blends on whiteboard <p>Additional Resources</p> <ul style="list-style-type: none"> • Balloon Ride Activity: using/identifying initial phonemes 	<p>Independent</p> <ul style="list-style-type: none"> • Letters and Sounds Activity printouts focusing on g, o, c, k sounds, supporting whole-class teaching and learning • Going Spare Activity/Activity Sheet <p>1:1 AFL</p> <ul style="list-style-type: none"> • ABC... Activity Sheet: Can children recognise letter names and initial phonemes? <p>Additional Resources</p> <ul style="list-style-type: none"> • Balloon Ride Activity: using/identifying initial phonemes
Mathematics	Number Shape, Space & Measure	<p>SECURING</p> <p>Class Activity</p> <ul style="list-style-type: none"> • Busy Bees - sing and count to 10 video • EXT: Five in a Bed Video - count down from 5 <p>Group Activity(ies)</p> <ul style="list-style-type: none"> • Counting Bugs Activity - count the bugs as a class, encourage children to count using fingers • EXT: Eggs for Breakfast Activity: counting to 10 <p>NEW UNIT</p> <p>Class Activity</p> <ul style="list-style-type: none"> • Swift Shop Learn Screen leading to Money Activity <p>Group Activity(ies)</p> <ul style="list-style-type: none"> • Swift Shop Activity - use plastic coins to reinforce visual learning 	<p>Independent</p> <ul style="list-style-type: none"> • Counting Bugs Activity Sheet • Counting Topic Tool - count the fish • Splash Out Activity - total coins to 10p <p>1:1 AFL</p> <ul style="list-style-type: none"> • Tractor Race Activity and Activity Sheet - ordinal numbers (small group or independent). Links to colours. • Eggs for Breakfast Activity Sheet • Money Topic Tool - Use coins to make 20p <p>Outdoors</p> <ul style="list-style-type: none"> • Set up shop in theme corner and children can use money to 'buy' items - include different fruits for children to feel and smell. Healthy eating links.
Expressive Arts & Design	Exploring & Using Media & Materials Being Imaginative	<ul style="list-style-type: none"> • Model making of a butterfly • Grow a plant from a seed - model to class - small group activity 	<ul style="list-style-type: none"> • Group-Led - Create a wristband using Make a Wristband Activity printout • Make a Shop Activity • Make a butterfly - painting and collage
Home Learning	Literacy Mathematics	<ul style="list-style-type: none"> • Let's Sketch Plants Student Tool - write a description of your plant • Let's Sketch Shapes Student Tool - identify the shapes used and discuss the end result with an adult. <p>Science Link - what sort of bugs would live here?</p>	



Name: _____ Class: _____

Draw something that makes you feel happy and something that makes you feel sad.
Do the same for a friend.

Me

	Happy
	Sad

My Friend

	Happy
	Sad

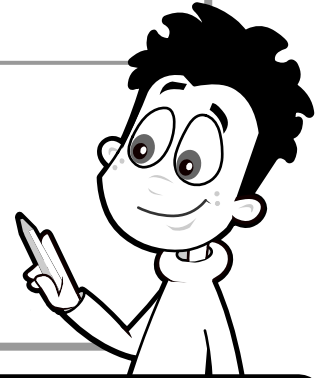

Draw a picture of you helping a friend when they are upset.
Think about what is upsetting them and how you might help them.



Name: _____ Class: _____

Draw something that makes you feel happy and something that makes you feel sad.
Do the same for a friend.

Me

	Happy
Accept all reasonable responses	
	Sad

My Friend

	Happy
Accept all reasonable responses	
	Sad

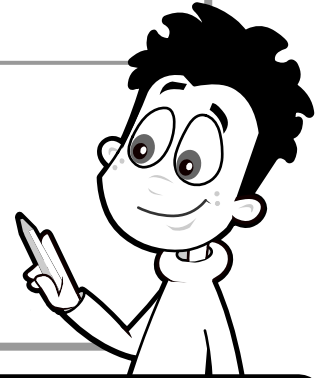

Draw a picture of you helping a friend when they are upset.
Think about what is upsetting them and how you might help them.

Accept all reasonable responses	
--	--



Name: _____ Class: _____

Choose an animal picture from the bottom of the sheet.

Colour it in and cut it out.

Where do you want to go?

Stick your animal on one of the pictures.

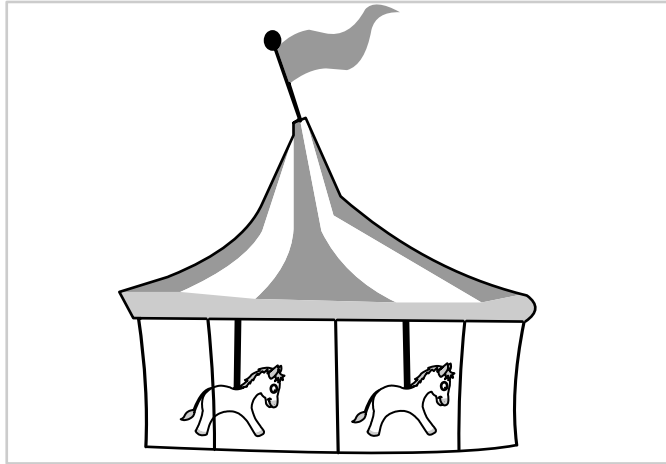

fairground

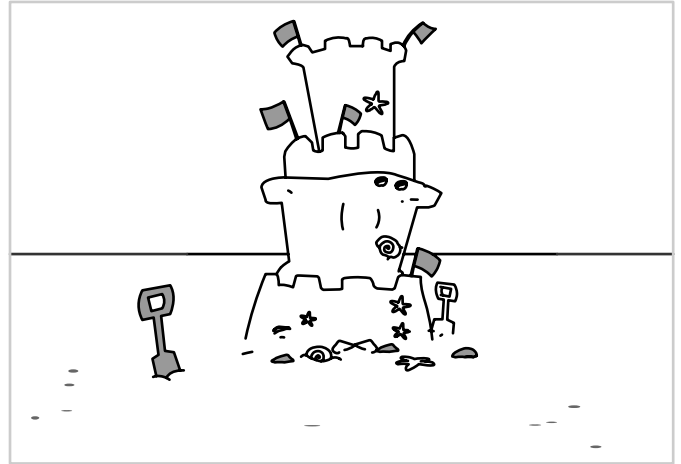

seaside

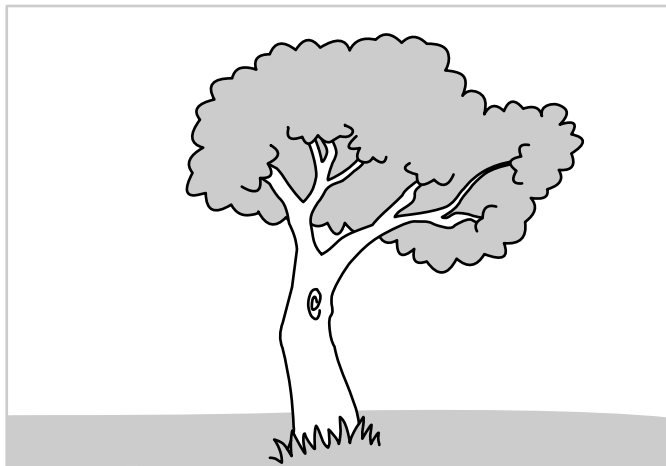

trees

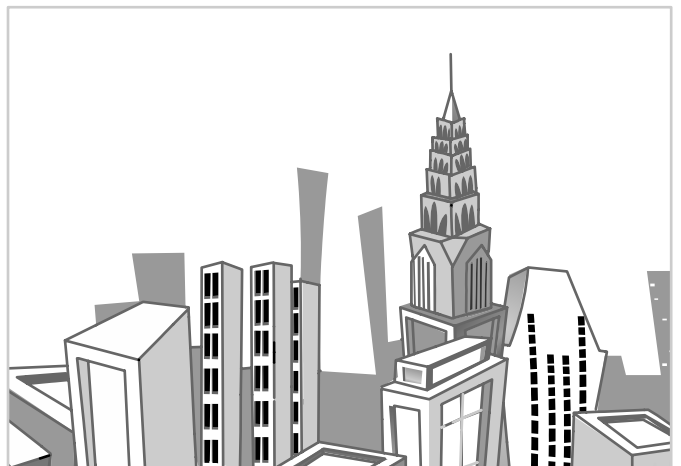

city

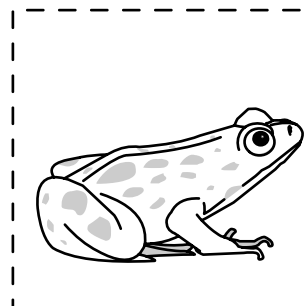
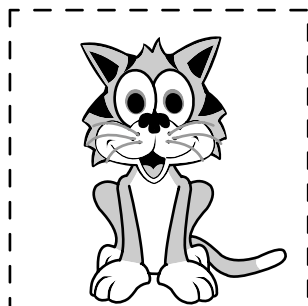
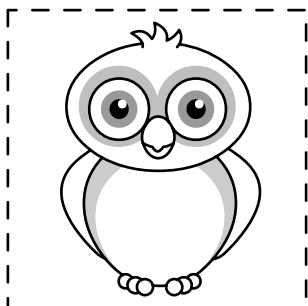



Name: _____ Class: _____



Say the letter name and sound. Then write it below.

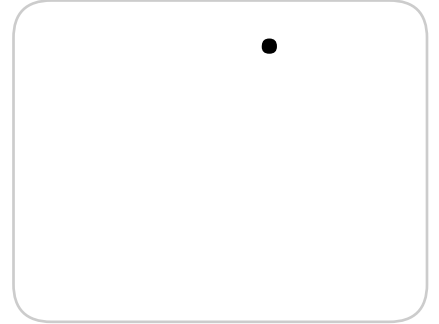
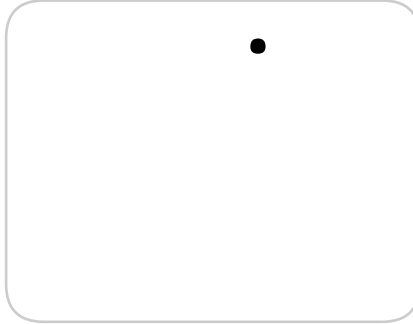
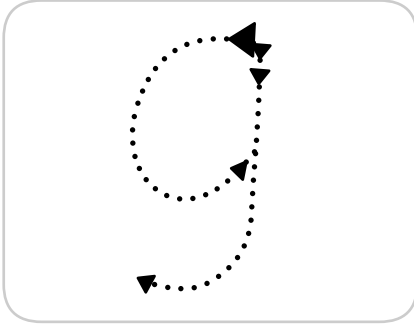

Look at the pictures. Say the words.
Finish writing the words using the letter g.

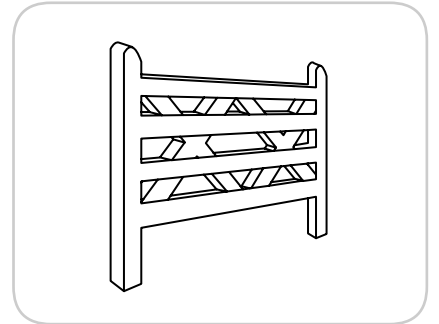
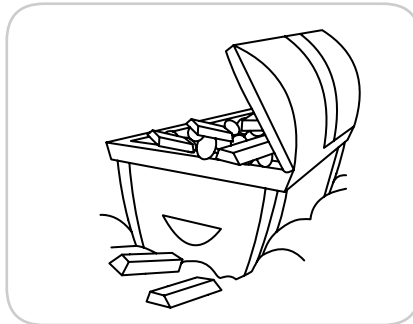
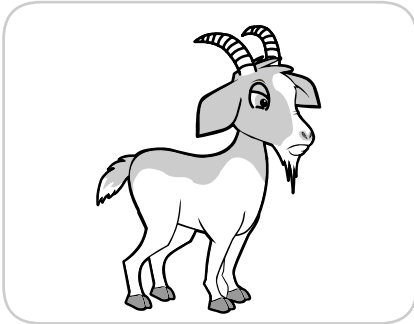

__ o a t

__ o l d

__ a t e



Write your own 'g' word on the line. Draw a picture.





Name: _____ Class: _____



Say the letter name and sound. Then write it below.

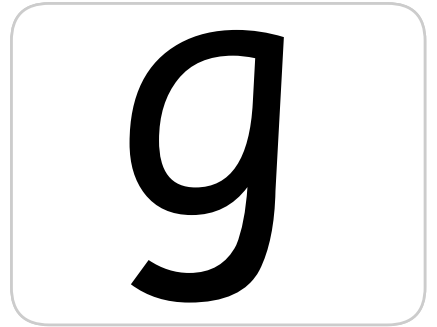
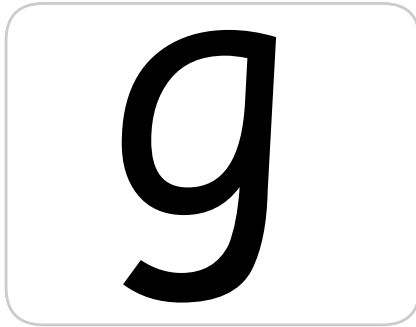
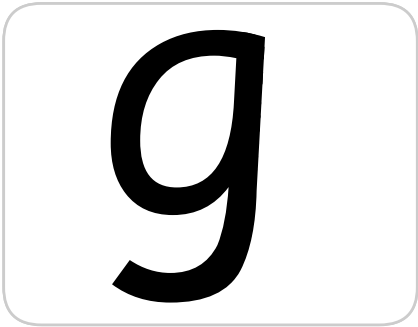

Look at the pictures. Say the words.
Finish writing the words using the letter g.

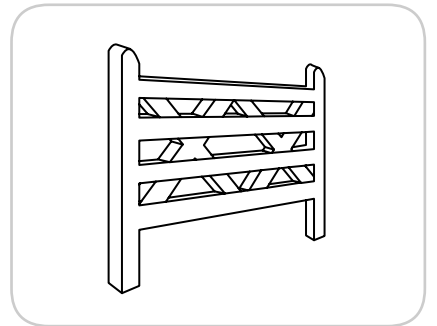
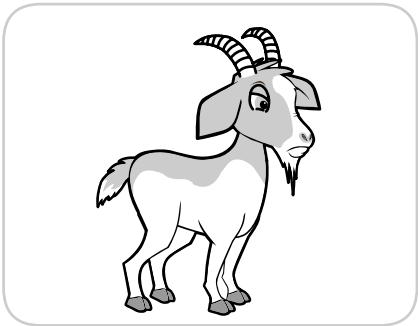

g o a t

g o l d

g a t e



Write your own 'g' word on the line. Draw a picture.

Any word beginning with a 'g'.

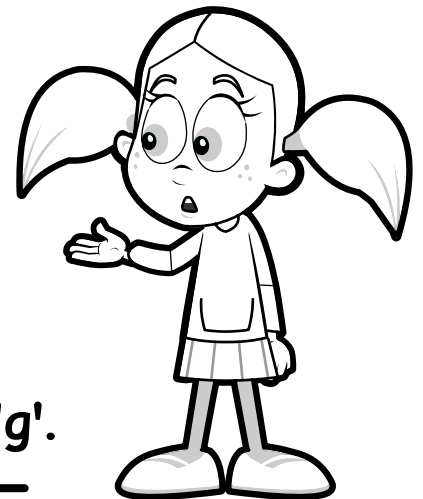



Name: _____ Class: _____



Say the letter name and sound. Then write it below.

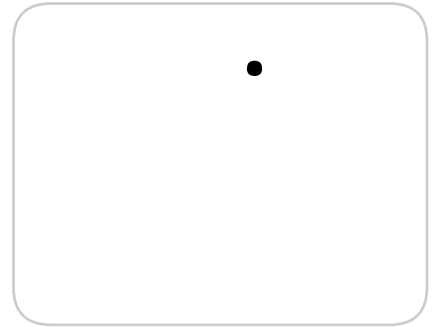
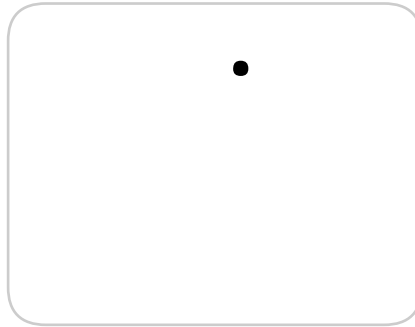
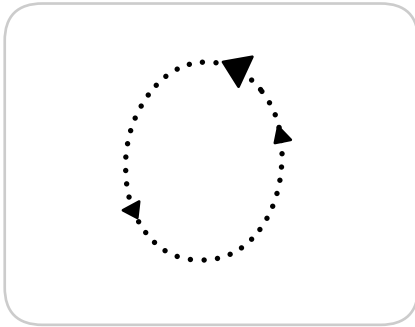

Look at the pictures. Say the words.
Write the missing letters to complete the words below.

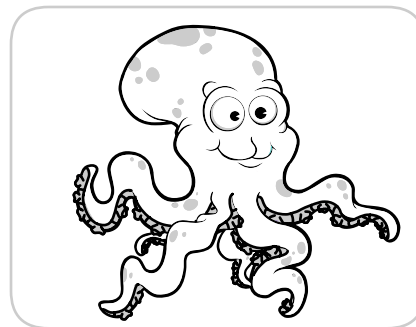
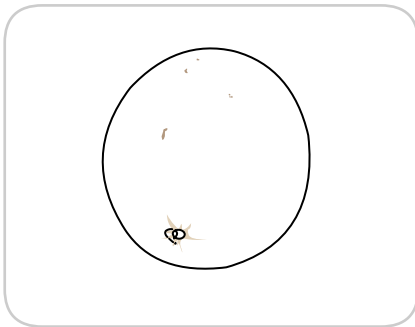



Write your own 'o' word. Draw a picture.



Name: _____ Class: _____



Say the letter name and sound. Then write it below.

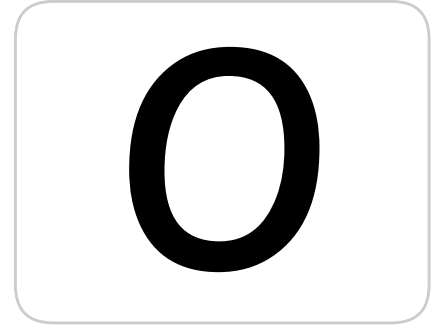
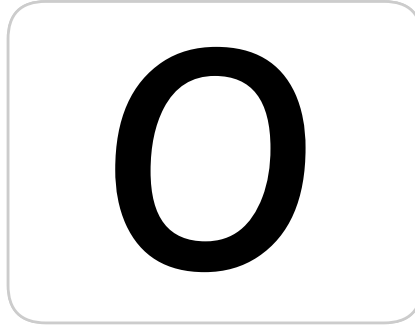
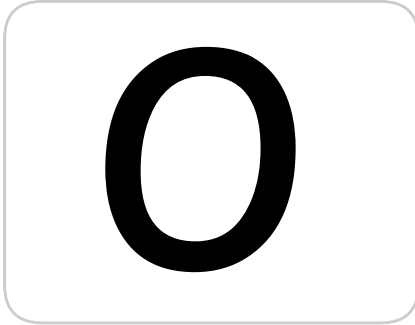

Look at the pictures. Say the words.
Write the missing letters to complete the words below.

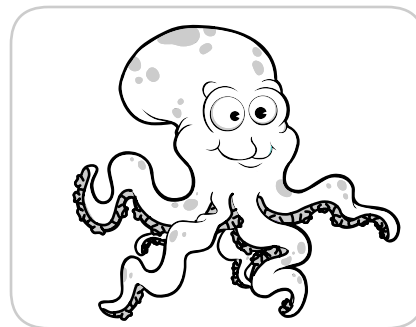
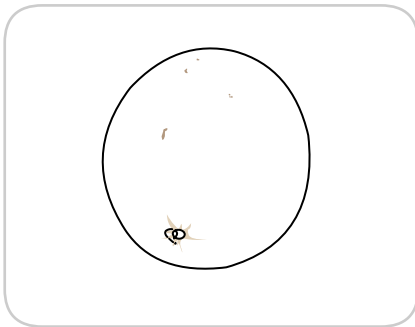

o r a n g e

o c t o p u s



Write your own 'o' word. Draw a picture.

Any word beginning with an 'o'.

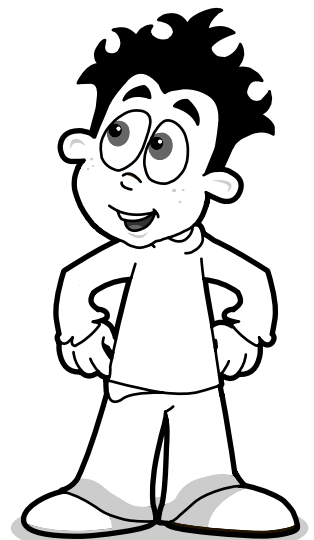



Curly Caterpillar

Activity Sheet

Name: _____ Class: _____



Say the letter name and sound. Then write it below.

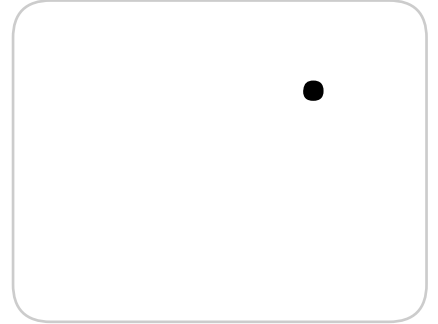
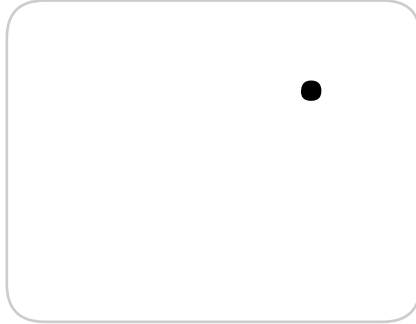
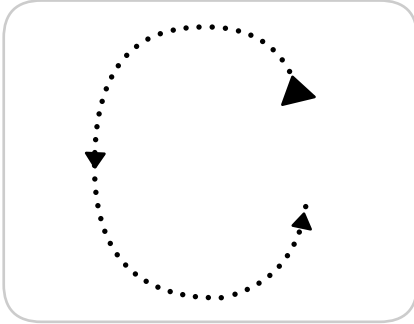

Look at the pictures. Say the words.
Write the words using the letters below.

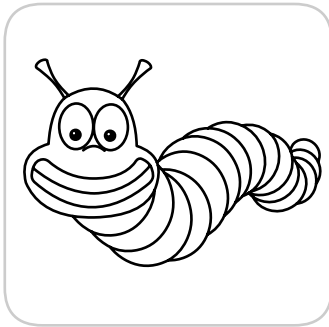

ap

a t e r p i l l a r



Write your own 'c' word. Draw a picture.

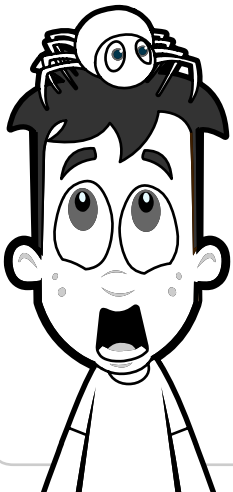
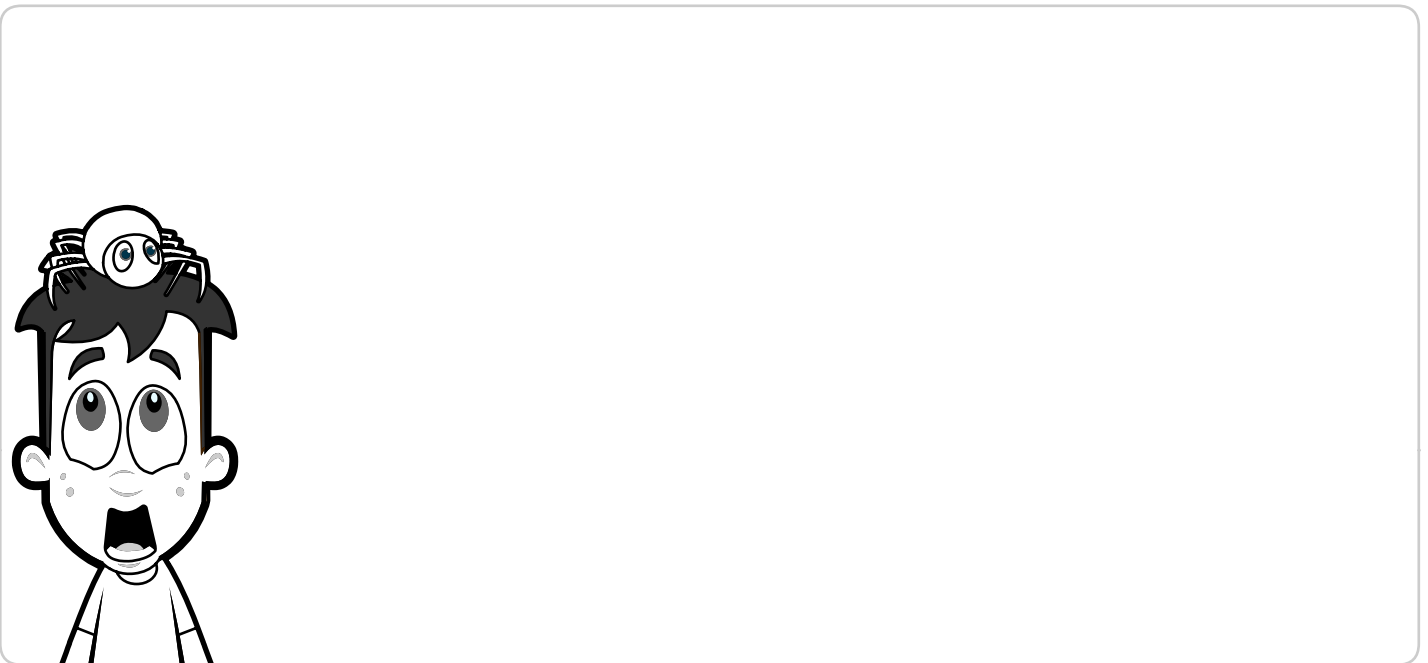



Name: _____ Class: _____



Say the letter name and sound. Then write it below.

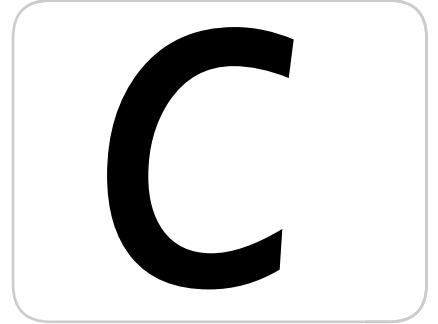
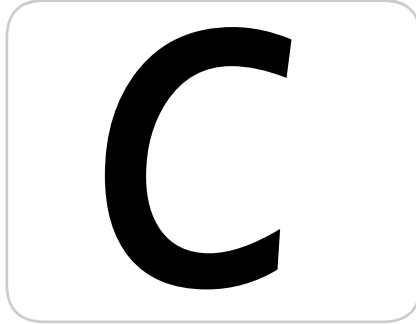
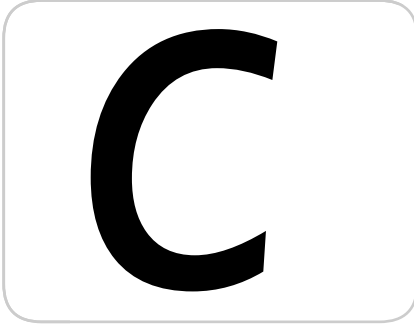

Look at the pictures. Say the words.
Write the words using the letters below.

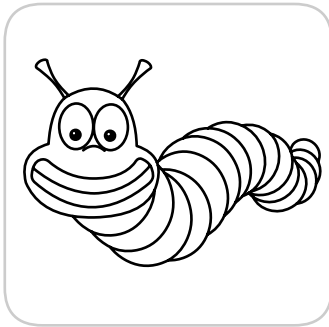
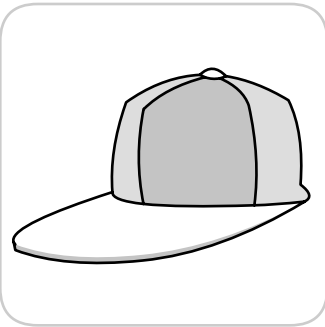

c a p

c a t e r p i l l a r



Write your own 'c' word. Draw a picture.

Blank area for writing a word and drawing a picture.

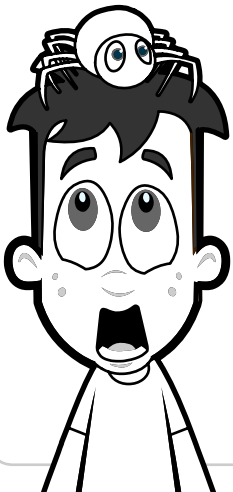

Any word beginning with a 'c'.



Name: _____ Class: _____



Say the letter name and sound. Then write it below.

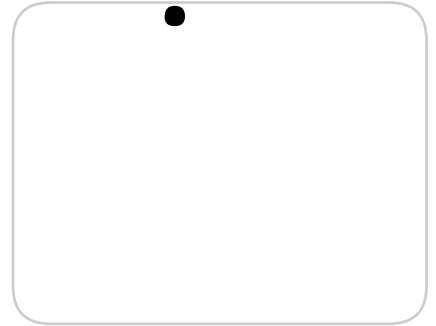
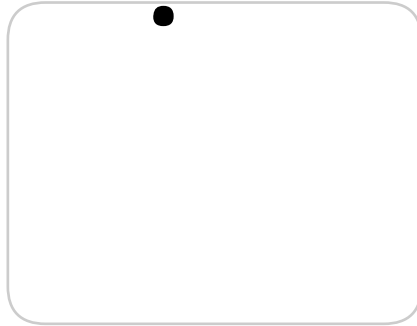
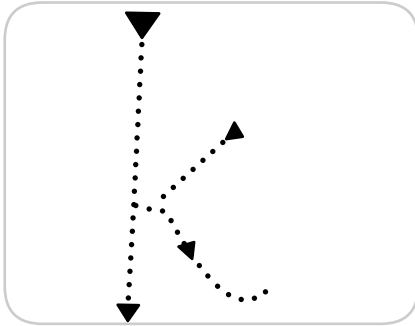

Look at the pictures. Say the words.
Write the words using the letters below.

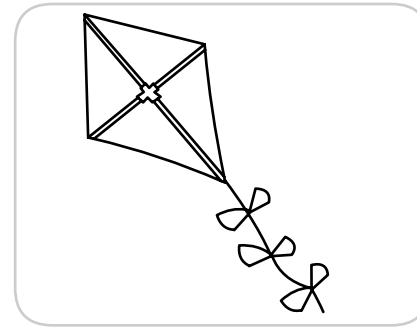
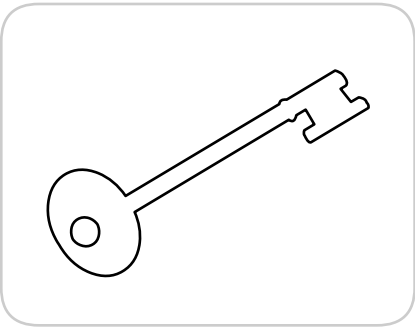

_____ e y _____

_____ i t e _____



Write your own 'k' word. Draw a picture.



Name: _____ Class: _____



Say the letter name and sound. Then write it below.

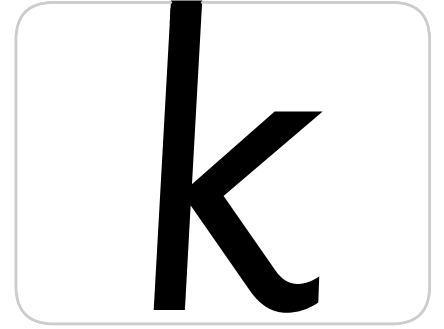
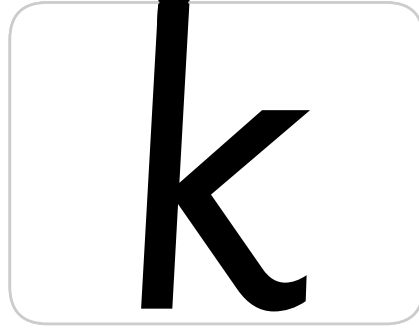
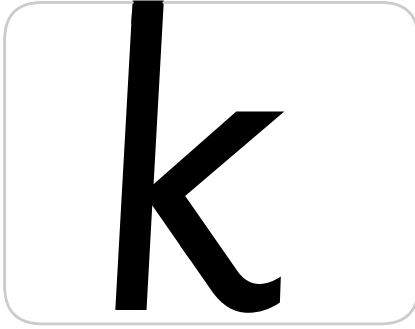

Look at the pictures. Say the words.
Write the words using the letters below.

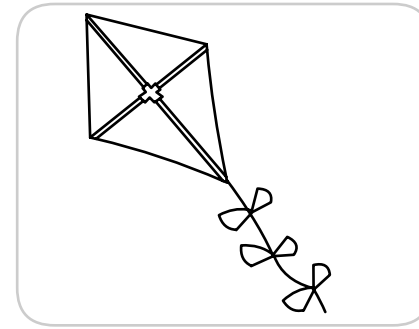
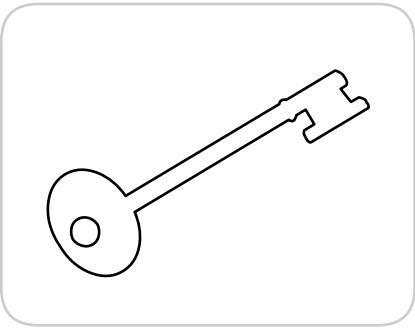

k e y

k i t e



Write your own 'k' word. Draw a picture.

Any word beginning with a 'k'.



Name: _____ Class: _____



Look at the pictures.

What capital letter does the word in the picture start with?

Circle the correct answer.

1

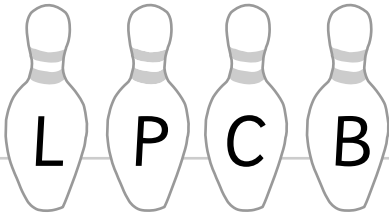

2

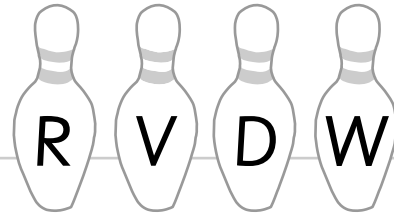
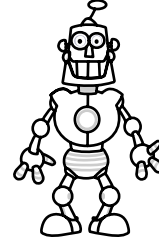

3

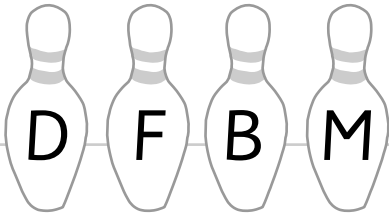
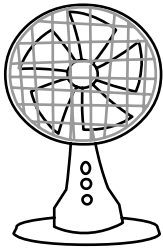

4

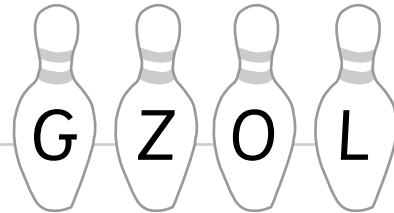
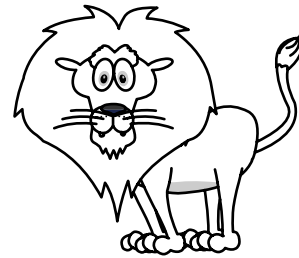

5

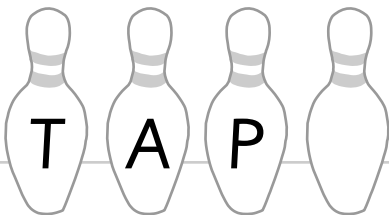
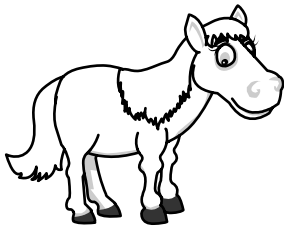

6

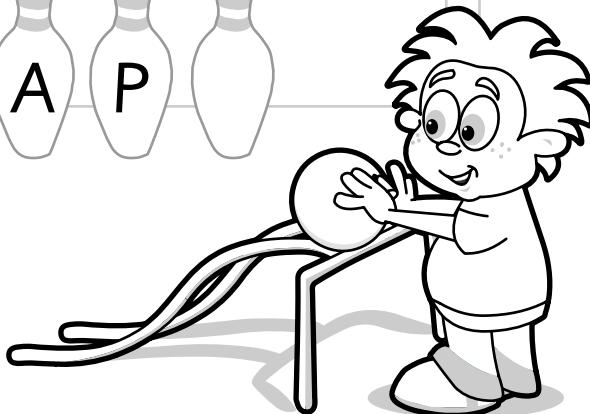
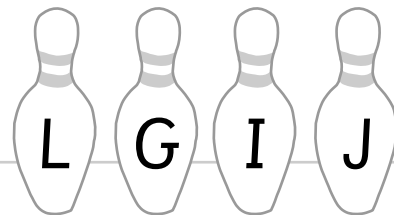
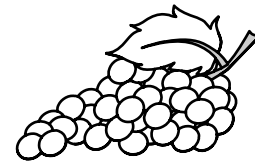



Name: _____ Class: _____



Look at the pictures.
What capital letter does the word in the picture start with?
Circle the correct answer.

1

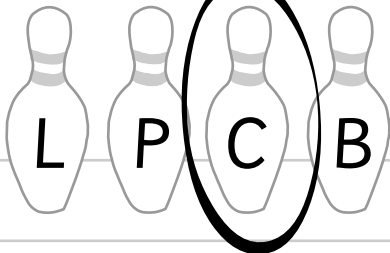

2

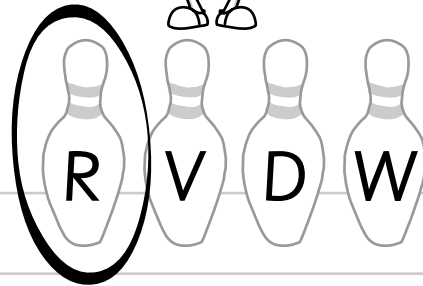
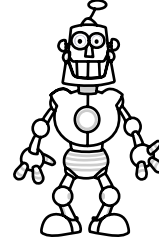

3

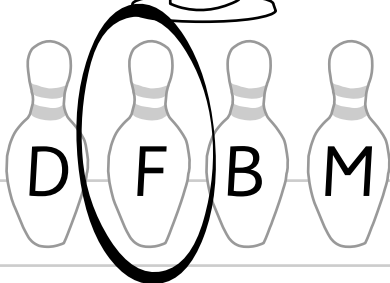
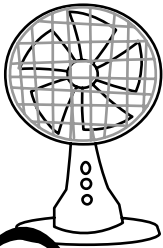

4

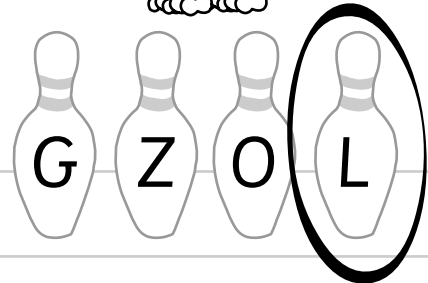
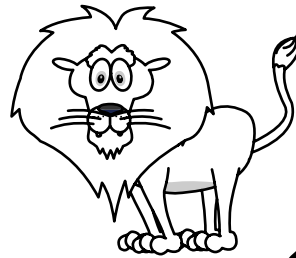

5

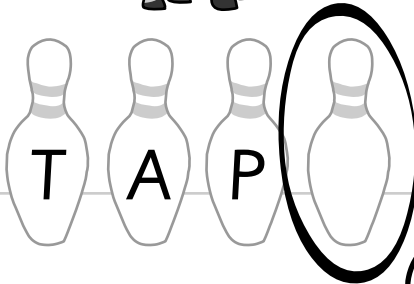
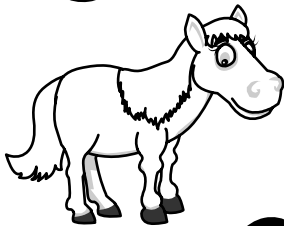

6

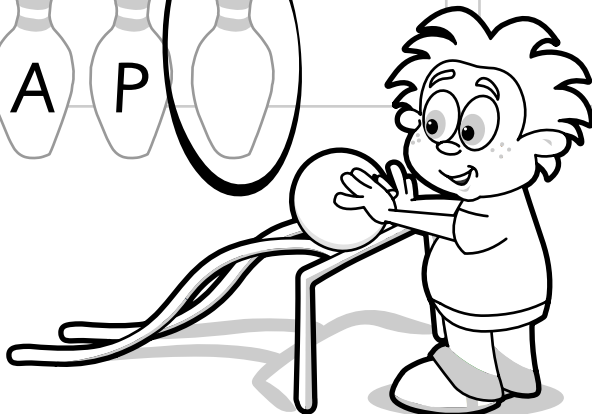
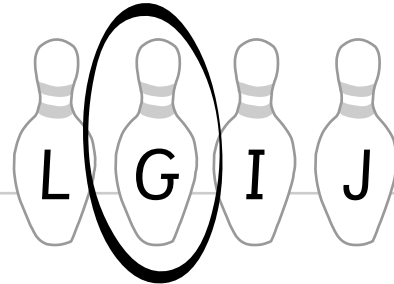
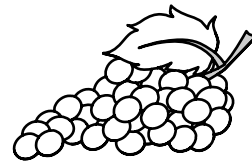



Name: _____ Class: _____

Can you sing the A B C song all the way through?
Point to the letter.

a b c d e f g
h i j k l m n
o p q r s t u
v w x y z

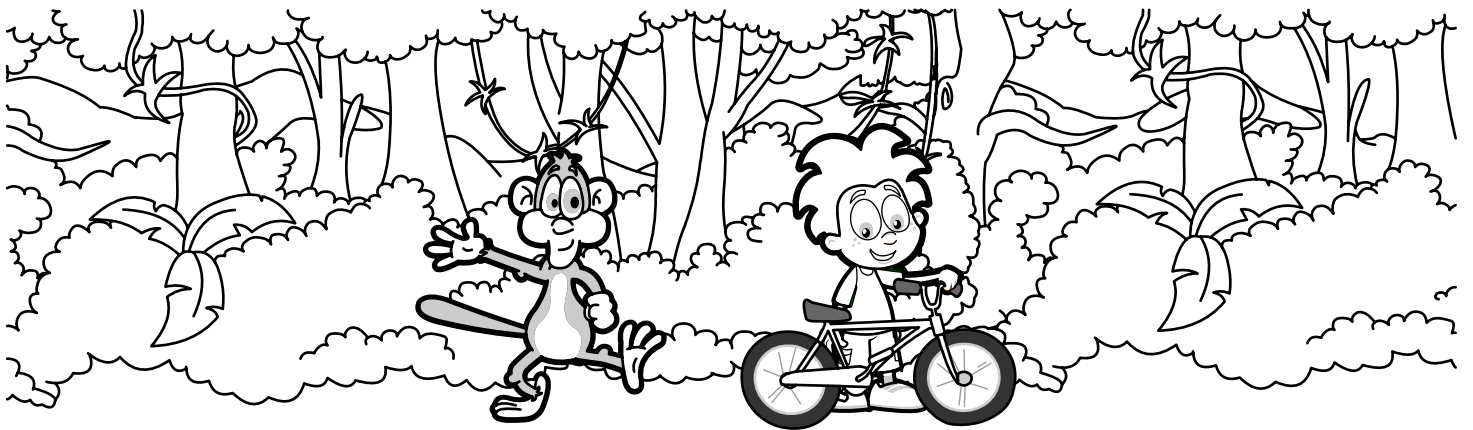

Teacher Notes

Sing the abc song and stop at various points.

Each time the teacher stops, the child points to the letter which should come next in the song.



Name: _____ Class: _____

Draw a line to match the picture to the letter it begins with.

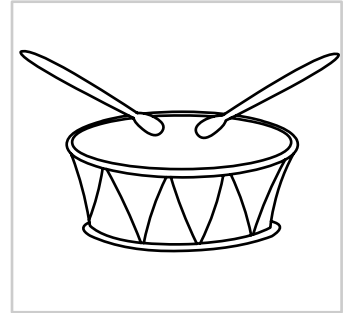
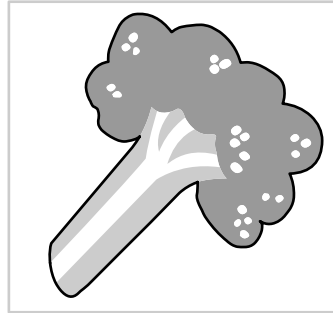
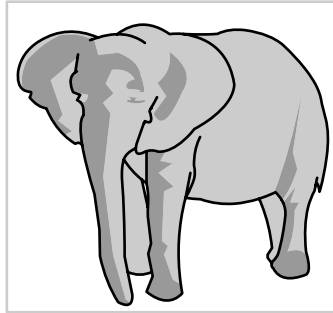
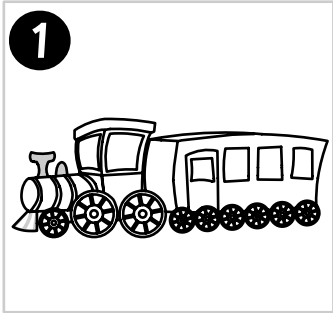

b

t

d

e

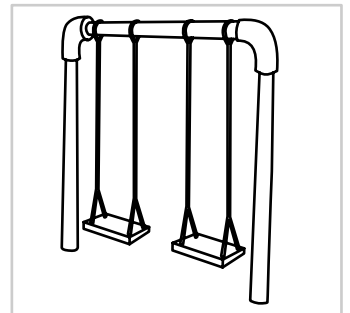
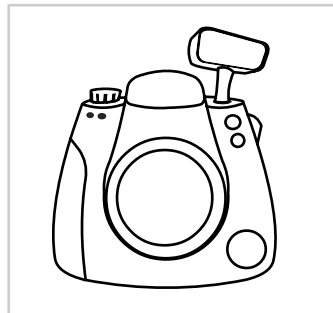
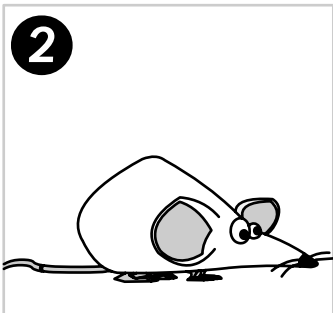

c

m

s

l

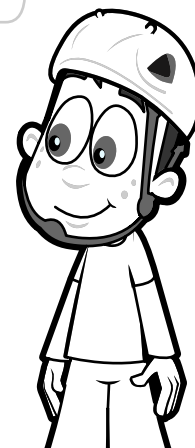



Name: _____ Class: _____

Draw a line to match the picture to the letter it begins with.

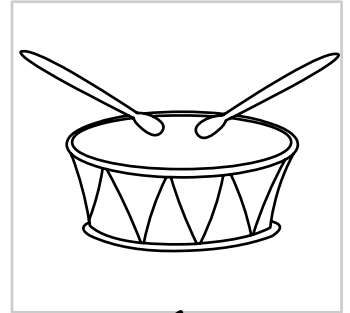
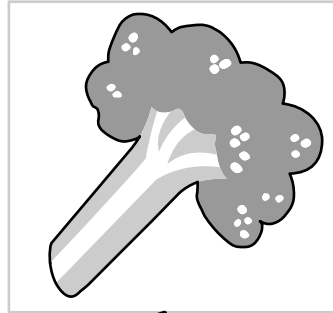
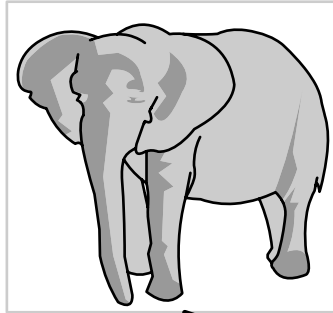
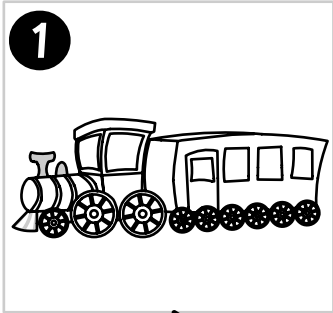

b

t

d

e

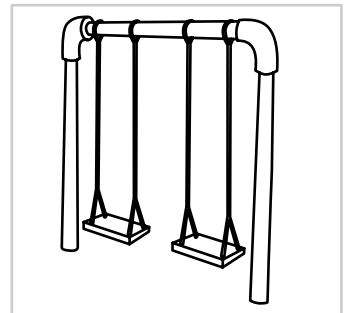
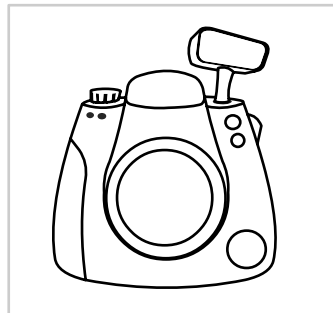
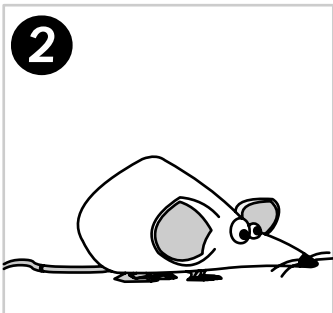

c

m

s

l

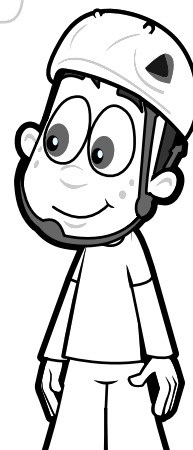



Name: _____ Class: _____

How many bugs do you see?
Write your answer on the line.

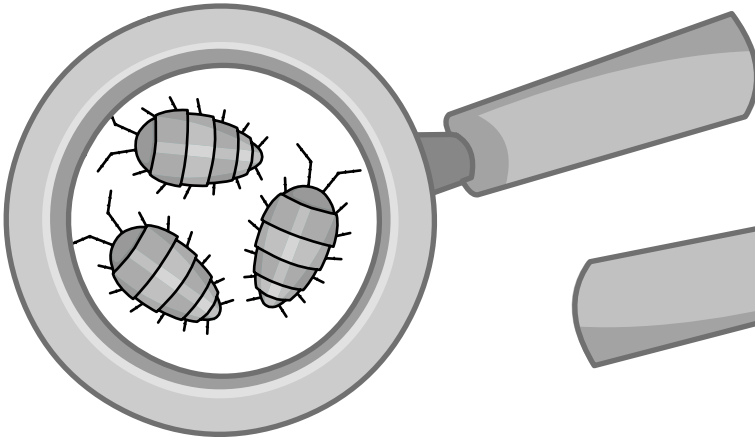

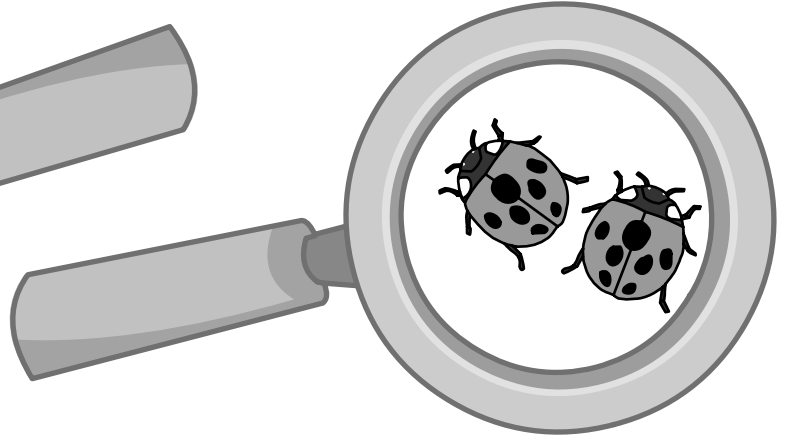

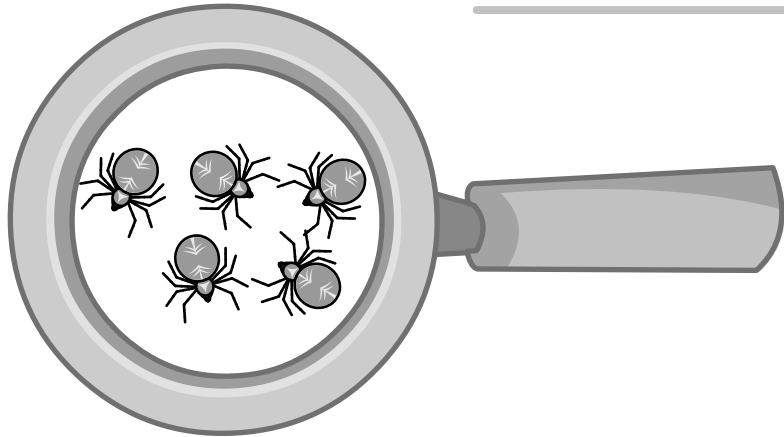
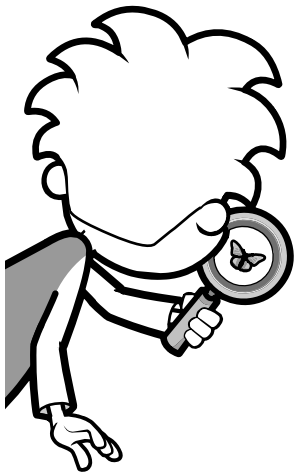

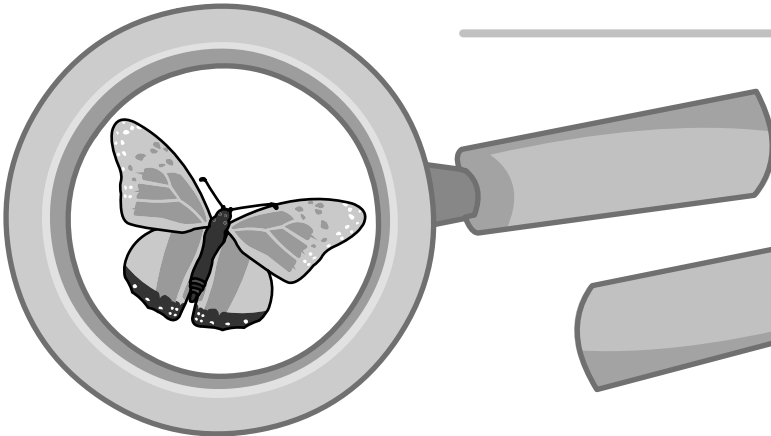

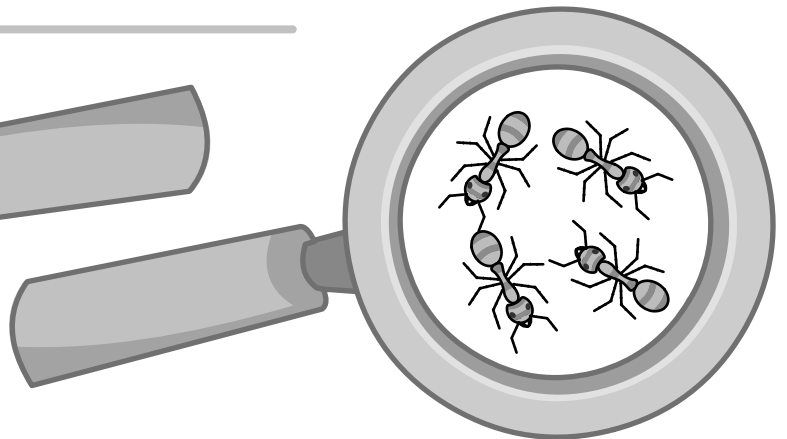



Name: _____ Class: _____

How many bugs do you see?
Write your answer on the line.

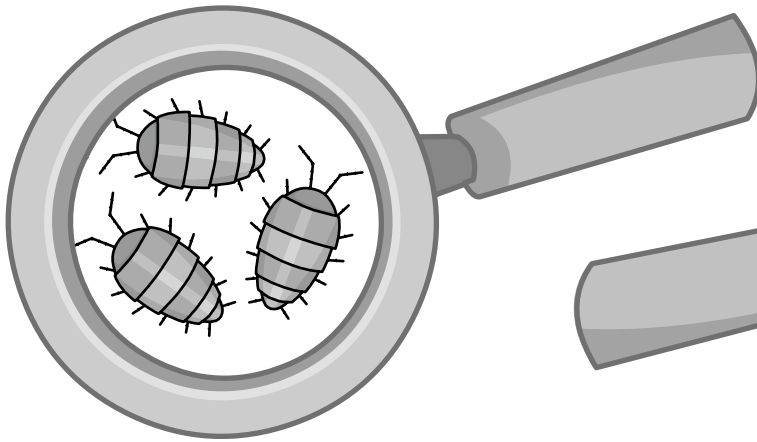

3



2

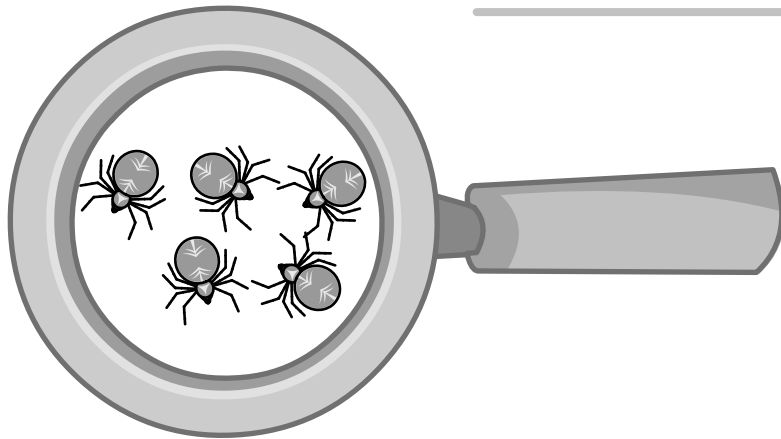
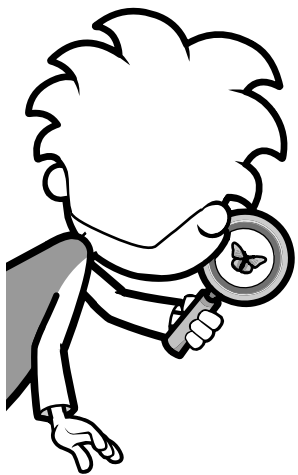

5

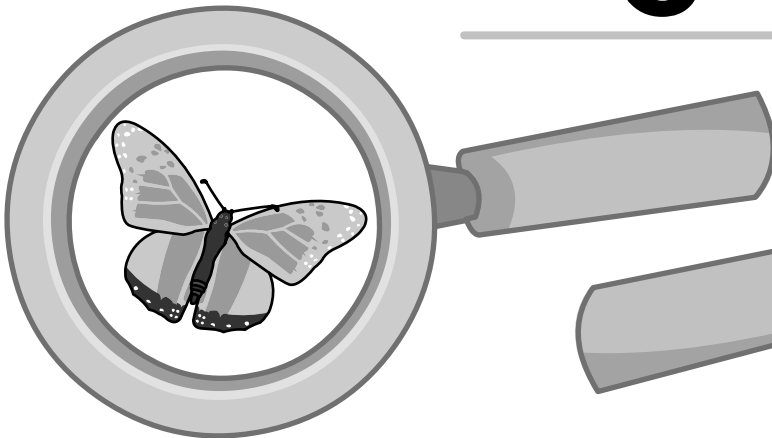

1

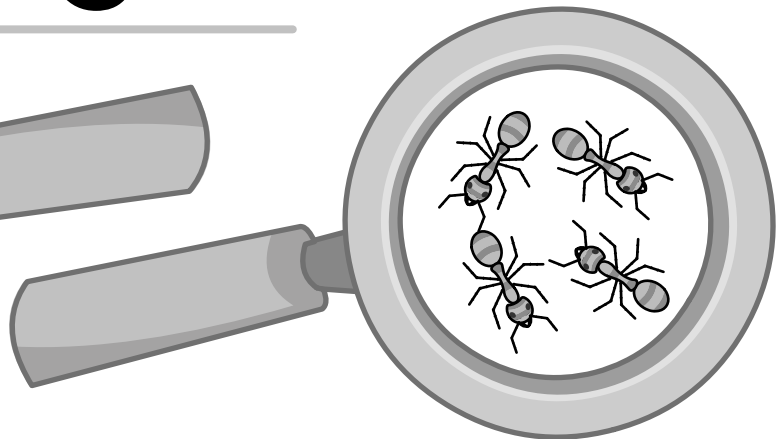

4



Name: _____ Class: _____

Listen to your teacher.

1

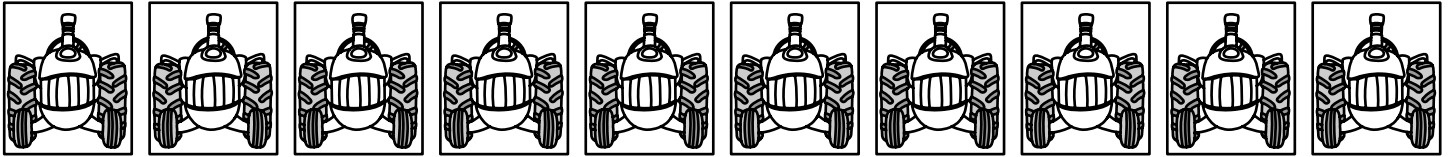

2

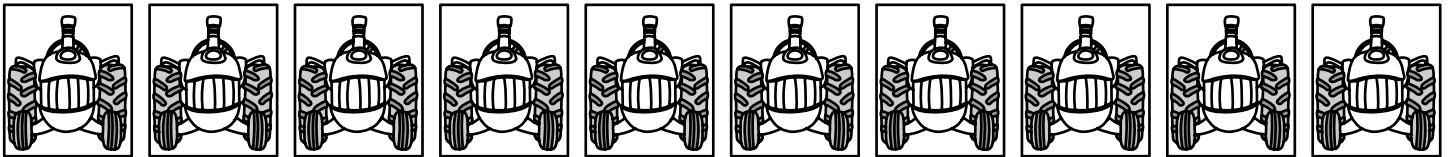

3

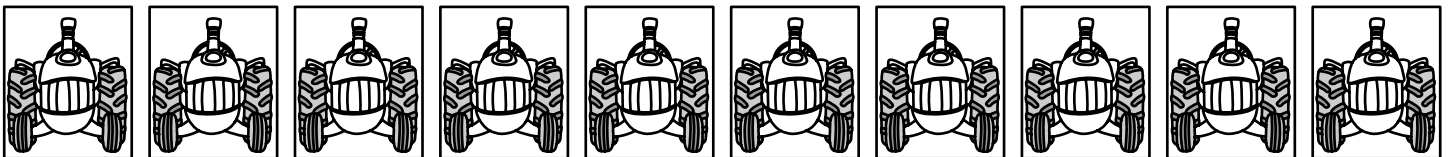

4

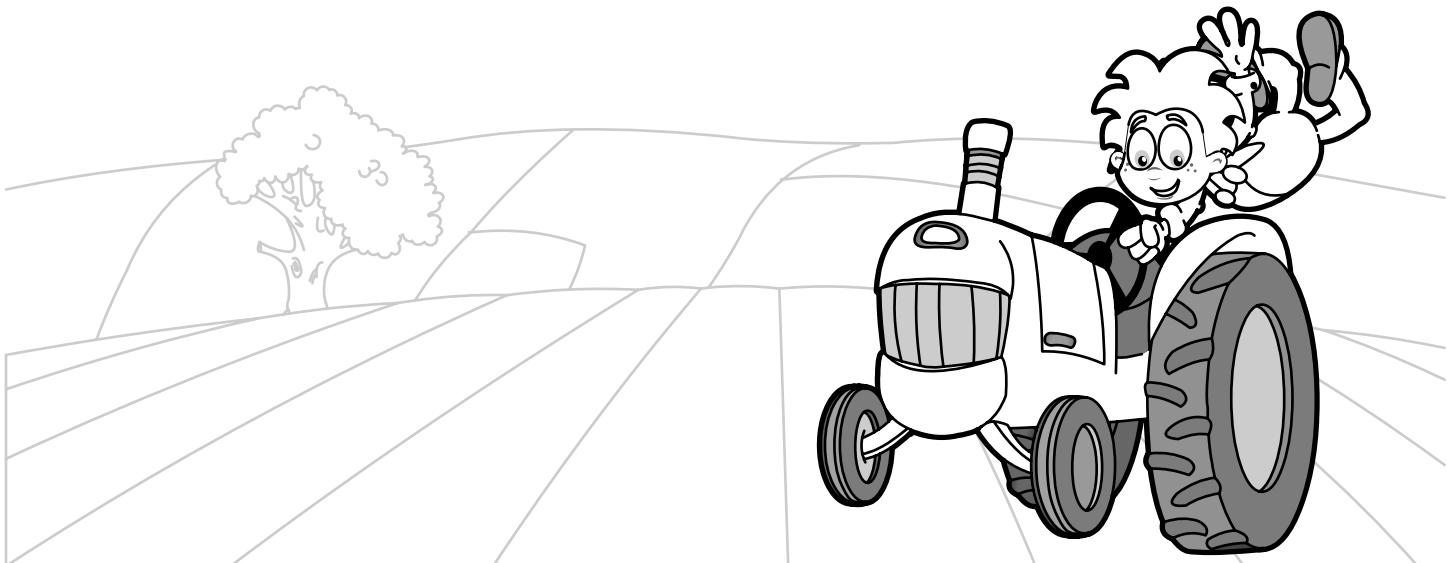
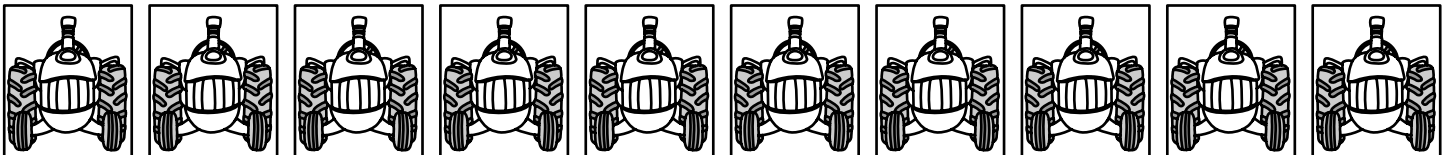

Directions: Q1. Colour the third tractor blue. Q2. Colour the sixth tractor green.
Q3. Colour the ninth tractor red. Q4. Colour the second tractor yellow.



Name: _____ Class: _____

Listen to your teacher.

1

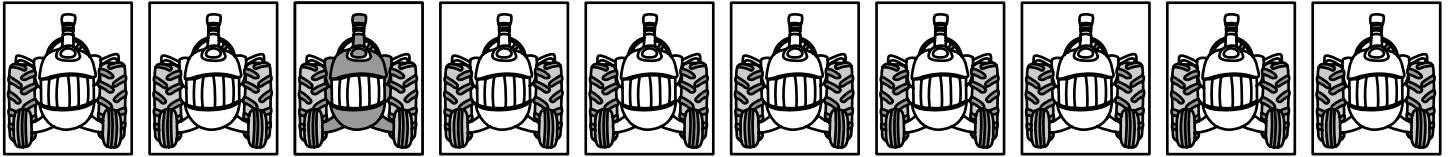

blue

2

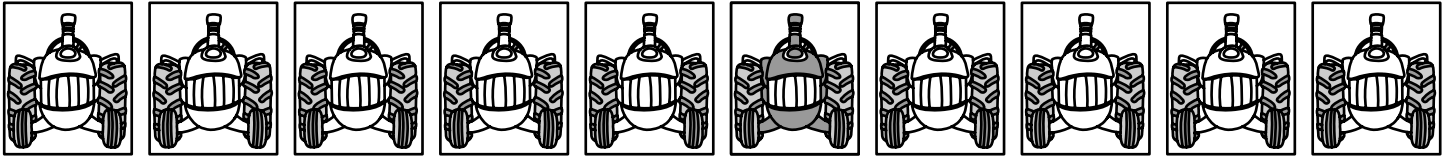

green

3

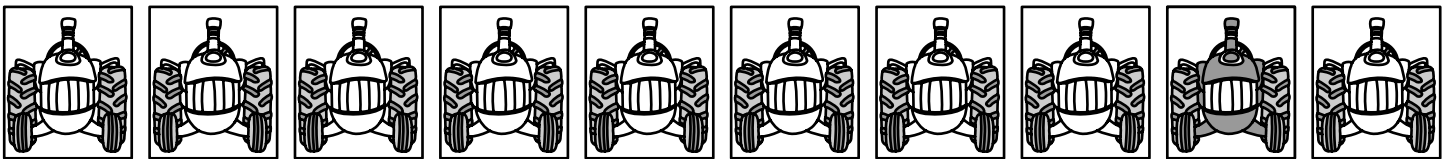

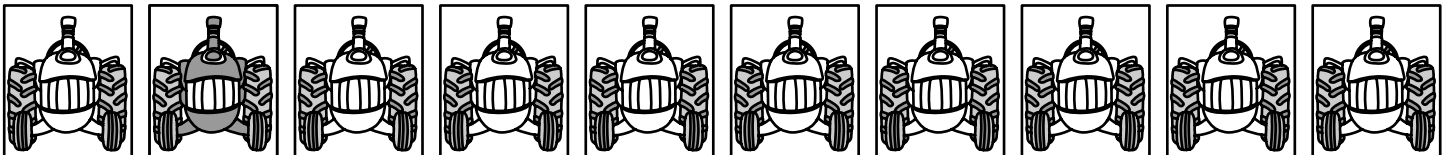

red

4

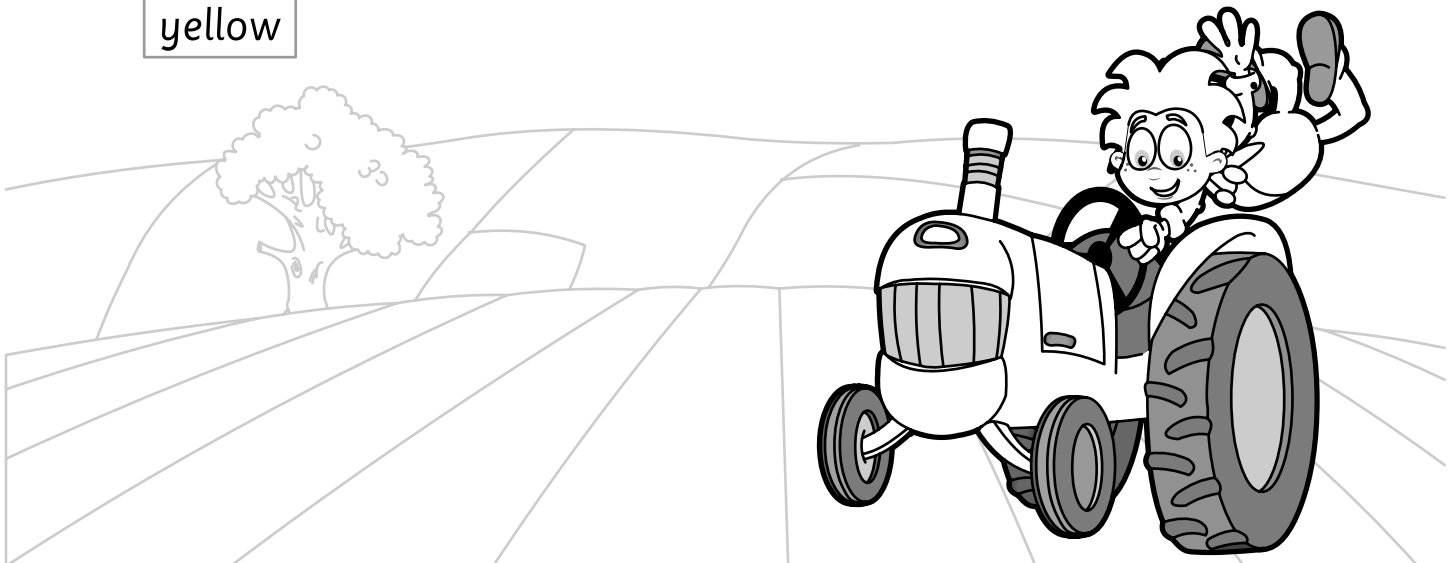

yellow



 **Directions:** Q1. Colour the third tractor blue. Q2. Colour the sixth tractor green. Q3. Colour the ninth tractor red. Q4. Colour the second tractor yellow.



Eggs For Breakfast

Activity Sheet

Name: _____ Class: _____

Count the eggs in each basket.
Write your answer on the line.

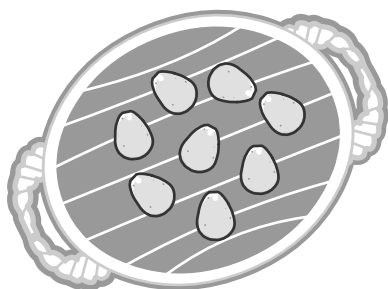

8

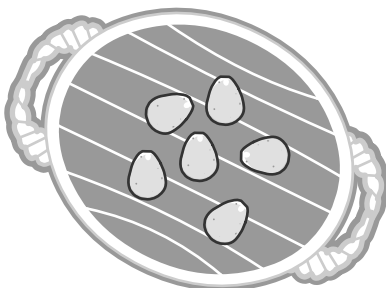

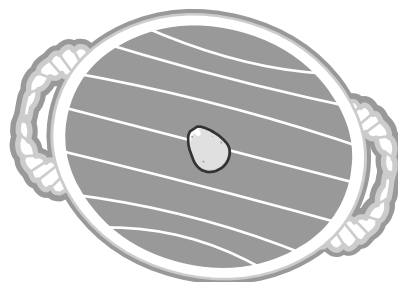

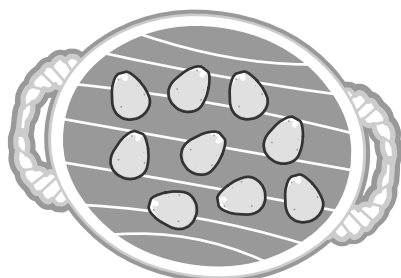

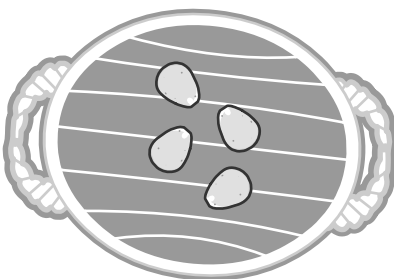

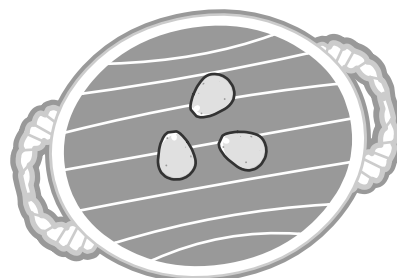

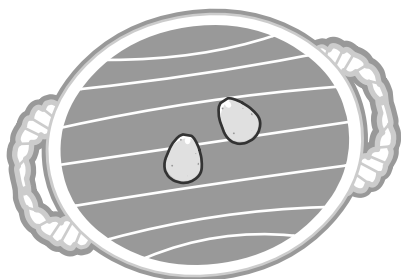

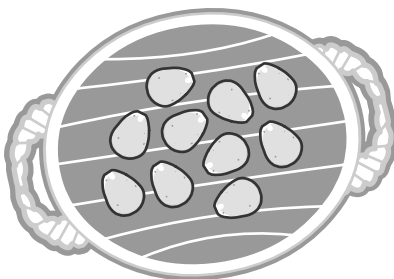

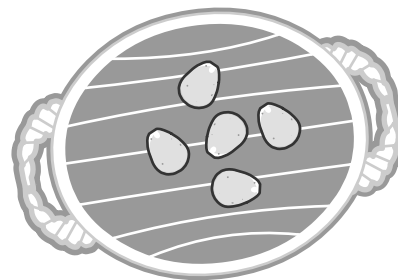

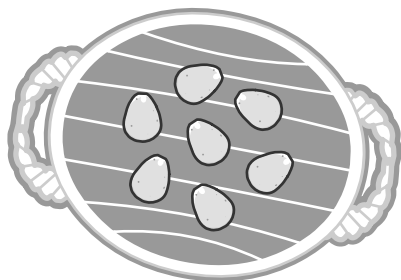

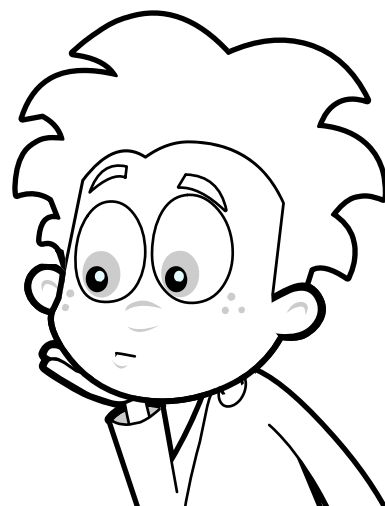
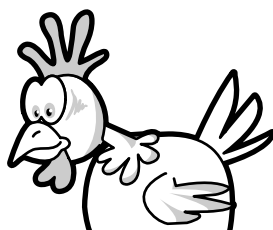



Name: _____ Class: _____

Count the eggs in each basket.
Write your answer on the line.

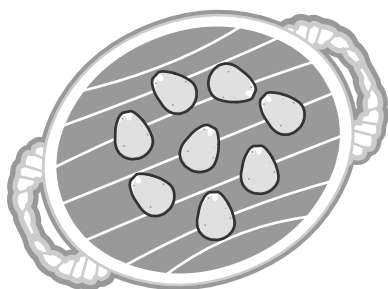

8

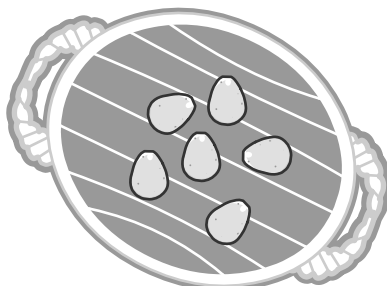

6

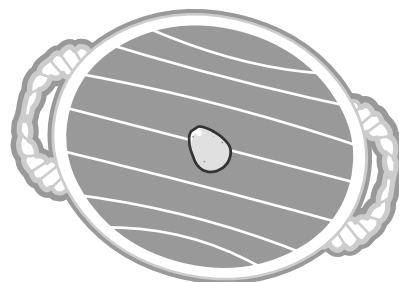

1

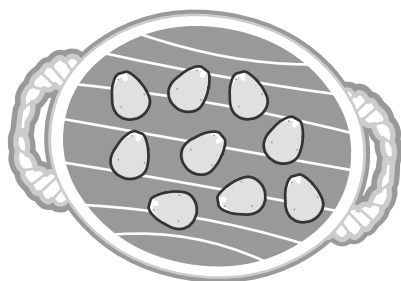

9

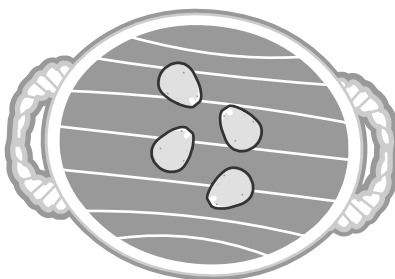

4

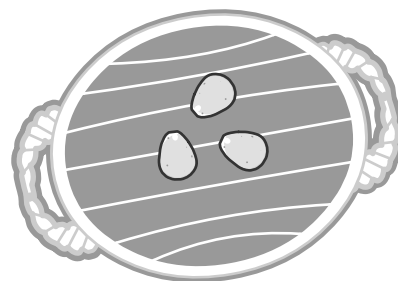

3

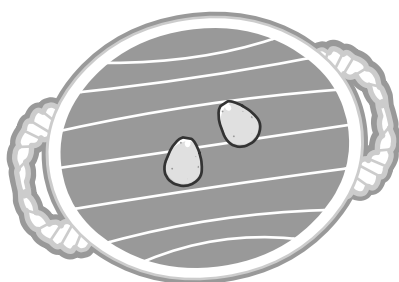

2

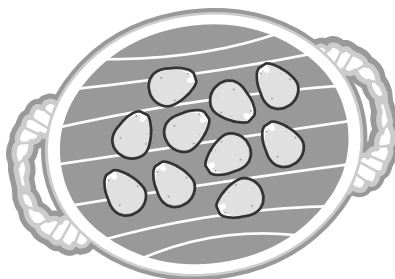

10

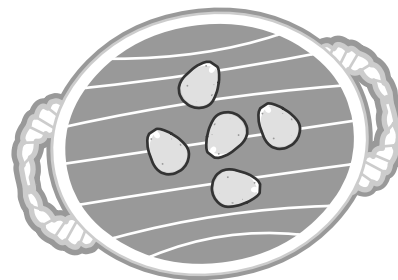

5

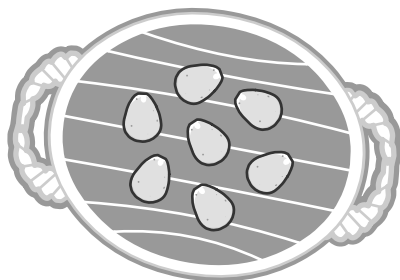

7

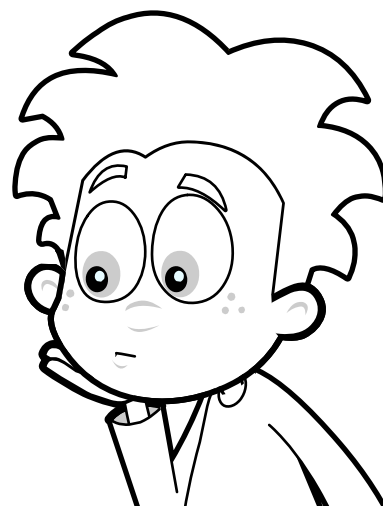
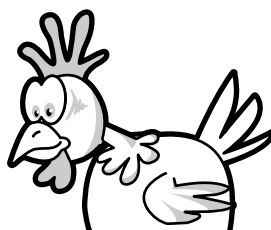



Make a Wristband

Activity Sheet

Name: _____ Class: _____

Cut out the shapes at the bottom of the sheet to decorate your wristband.
Colour it in.

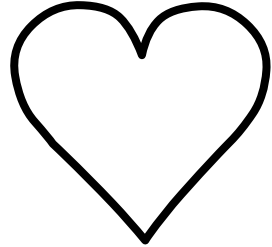
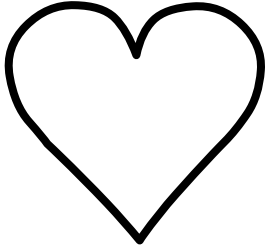
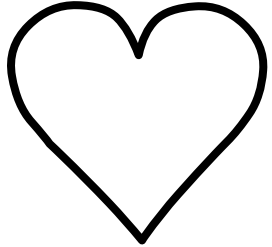
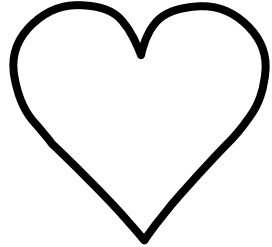
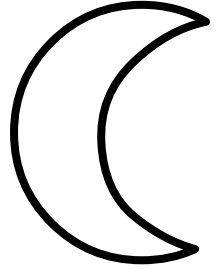
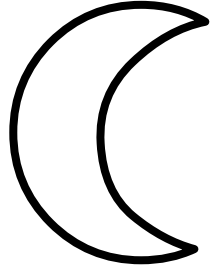
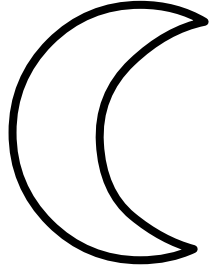
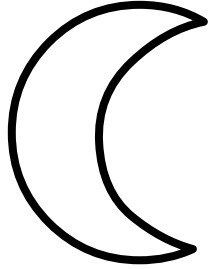
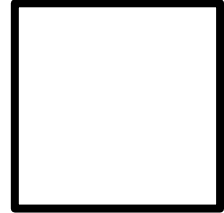
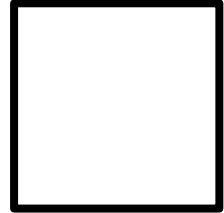
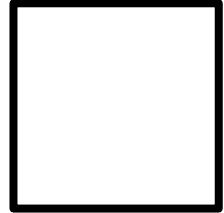
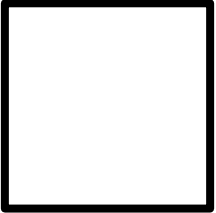
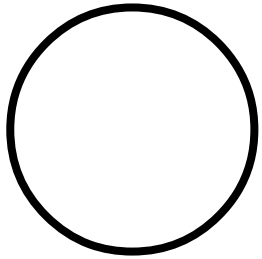
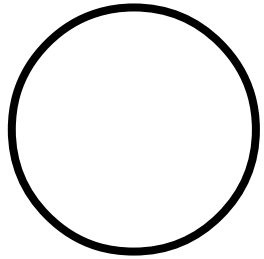
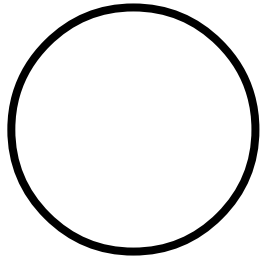
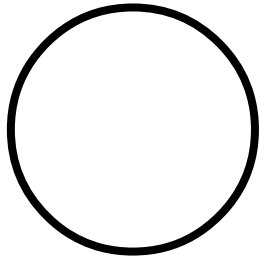

1

one

2

two

3

three

4

four

5

five

6

six

7

seven

8

eight

9

nine

10

ten

11

eleven

12

twelve

13

thirteen

14

fourteen

15

fifteen

16

sixteen

17

seventeen

18

eighteen





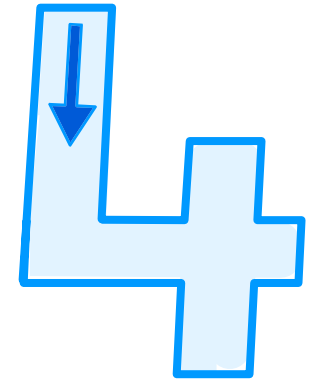
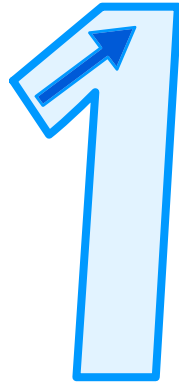
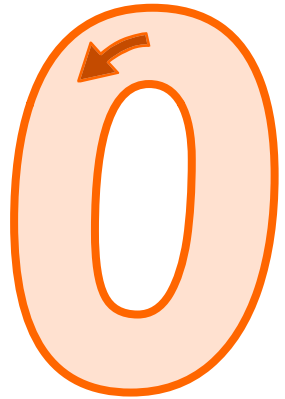

19

nineteen

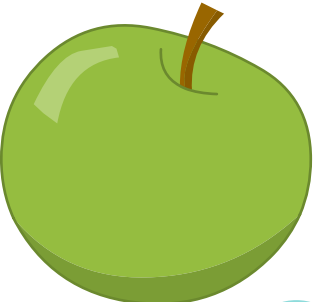
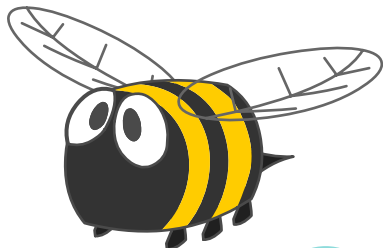
20

twenty

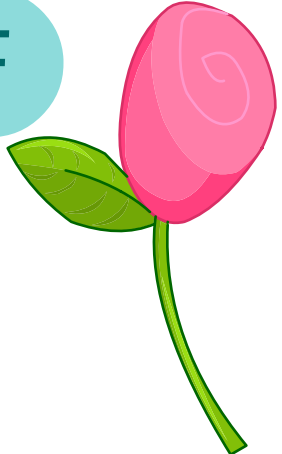
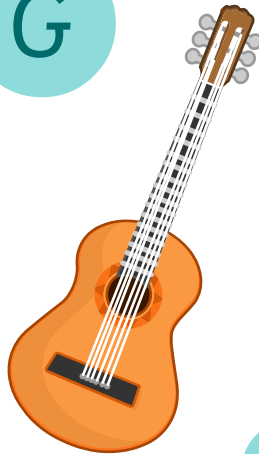
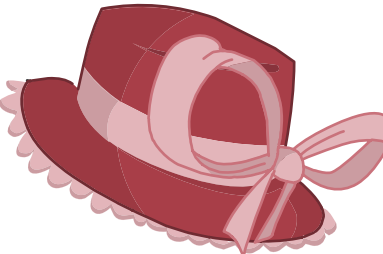

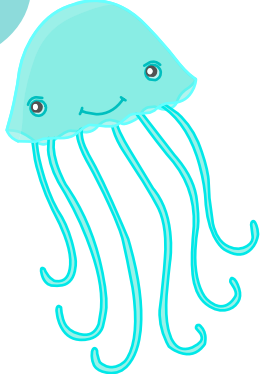
<p>A</p>  <p>a</p>	<p>B</p>  <p>b</p>	<p>C</p>  <p>c</p>	<p>D</p>  <p>d</p>	<p>E</p>  <p>e</p>
<p>F</p>  <p>f</p>	<p>G</p>  <p>g</p>	<p>H</p>  <p>h</p>	<p>I</p>  <p>i</p>	<p>J</p>  <p>j</p>

				
				

U



u

V

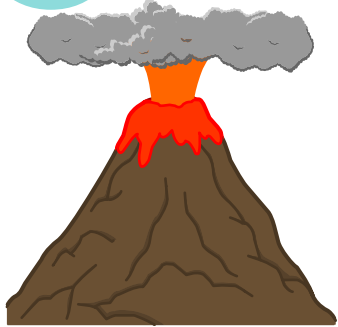

v

W



w

X



x

Y

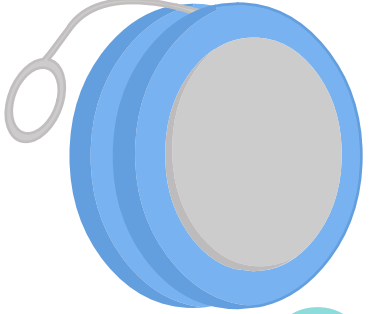

y

Z



z

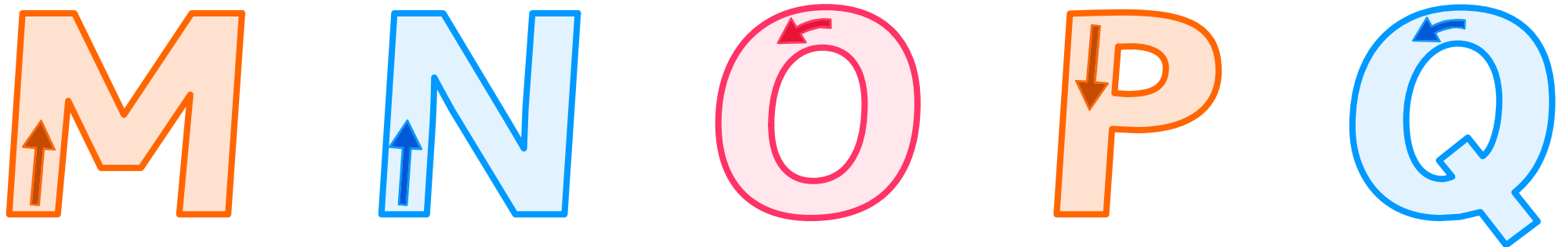
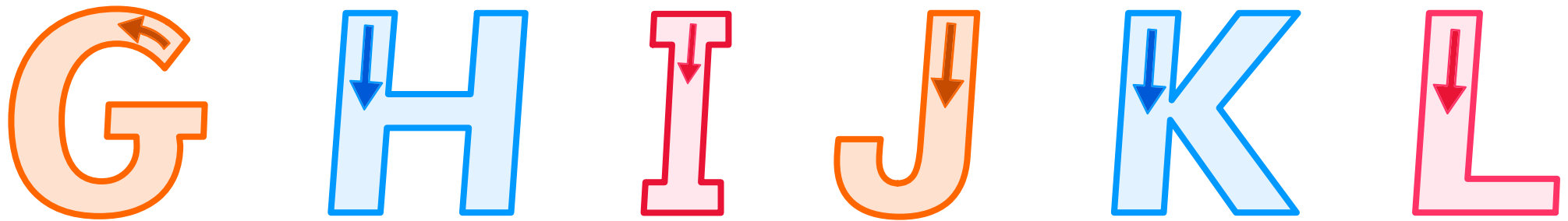
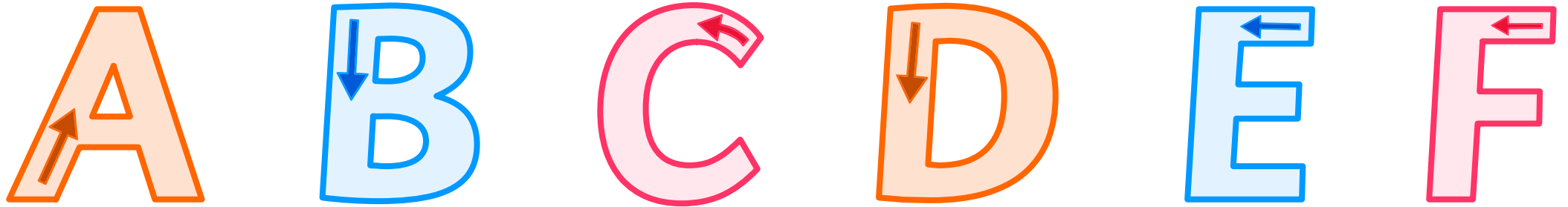

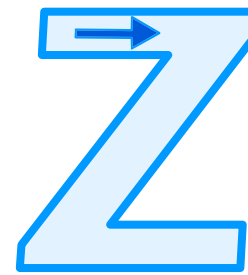
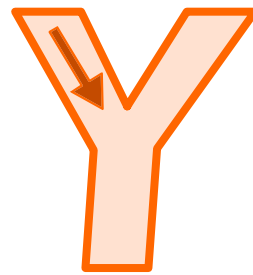
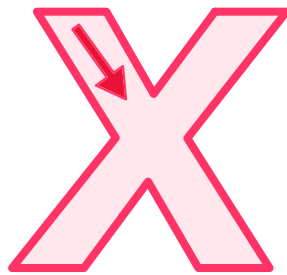
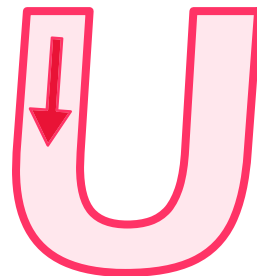
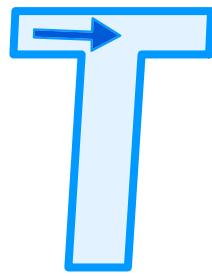
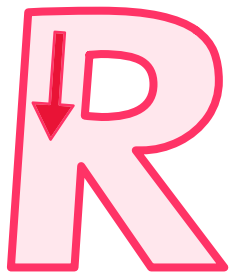

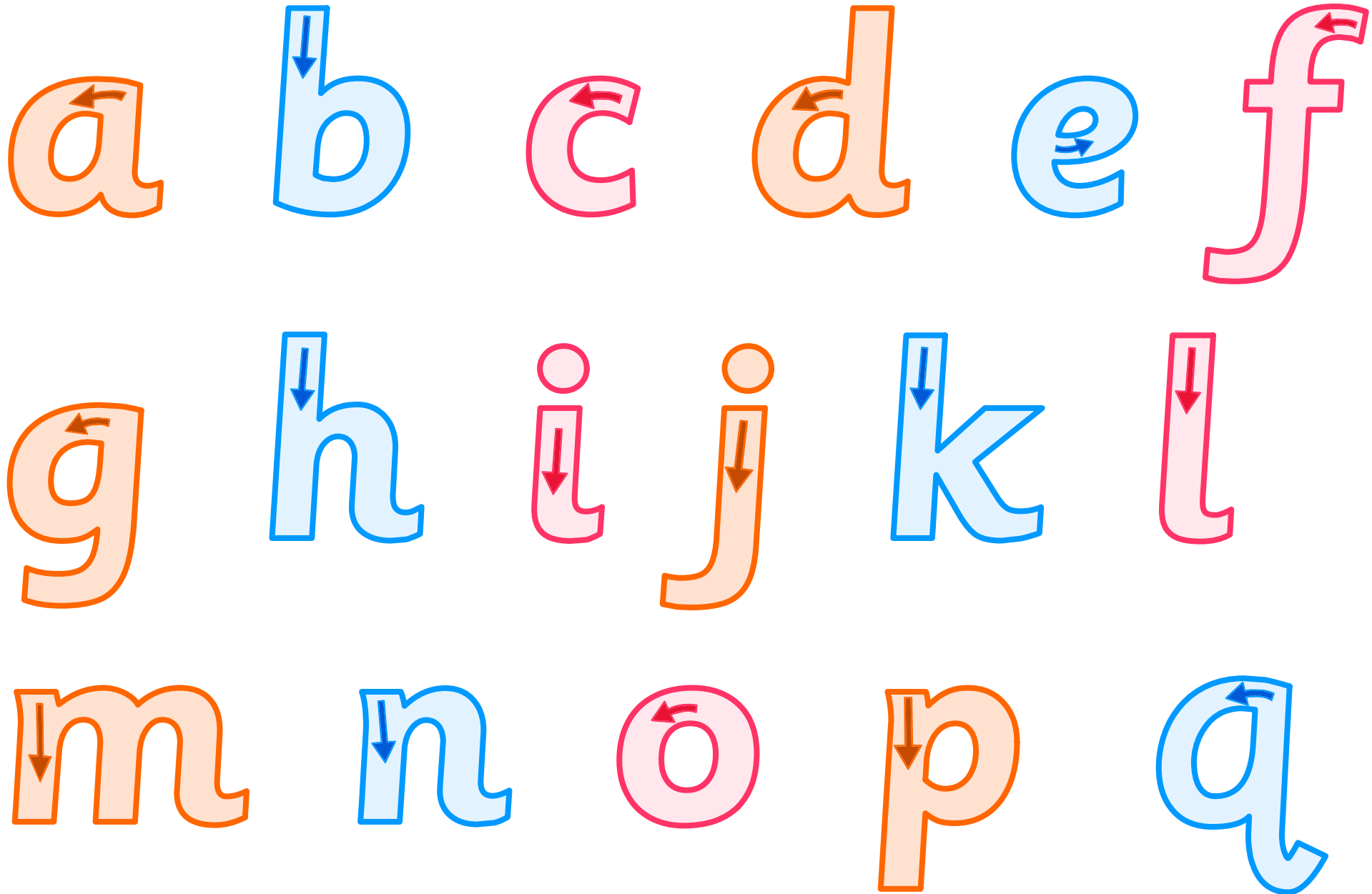

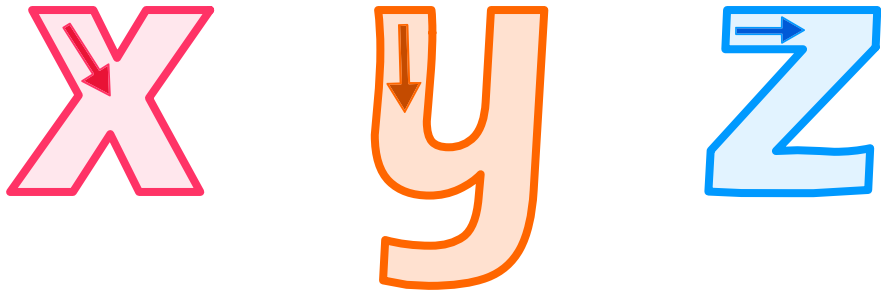
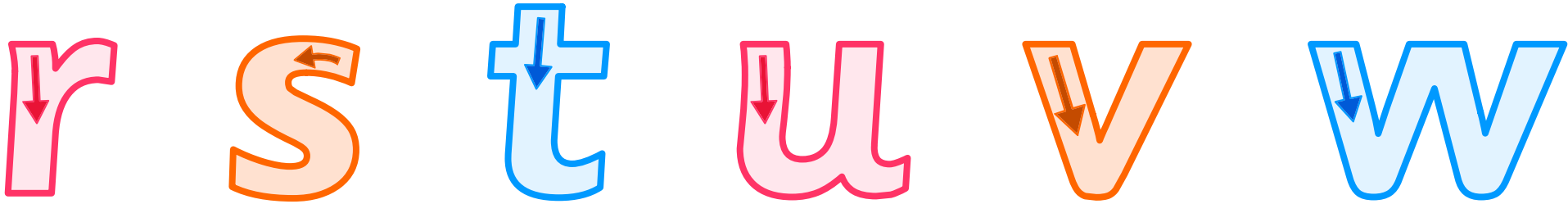



Letters and Sounds: High Frequency Words Checklist

(bold = tricky words)

Phase 2

a	an	as	at	if	in
is	it	of	off	on	can
dad	had	back	and	get	big
him	his	not	got	up	mum
but	the	to	I	no	go
into					

Phase 3

will	that	this	then	them	with
see	for	now	down	look	too
he	she	we	me	be	was
you	they	all	are	my	her

Phase 4

went	it's	from	children	just	help
said	have	like	so	do	some
come	were	there	little	one	when
out	what				

Phase 5

don't	old	I'm	by	time	house
about	your	day	made	came	make
here	saw	very	put	oh	their
people	Mr	Mrs	looked	called	asked
could					

About EducationCity

EducationCity produces fun, educational materials to engage students in learning and empower teachers to tailor their teaching. [Take a look at how EducationCity can support you in the classroom:](#)



Target Lesson Objectives Easily

Find relevant content that links to your curriculum by using our Curriculum Map or Search tool.

Comprehensive and clearly organised by strand, content is so easy to access!



Plan in Advance

When planning your lessons, choose your Activities in advance and put them into a MyCity so they're easy for students to access. Choose a meaningful name for each MyCity and you'll be able to update and retrieve them year after year!



Differentiated Teaching

Monitor progress with SuccessTracker and you'll be able to identify the strengths and areas of development for each of your students and so choose relevant activities to help them progress.



Flexible Learning

EducationCity is accessible via desktops, laptops, tablets and whiteboards, so can support you whatever equipment is available in your classroom.



Lesson Plans

Access our ready-made Lesson Plans, topical content and Teacher Resource Pack to support teaching and learning in the classroom.

There's more to EducationCity than Activities alone!



Blog

Keep abreast of events in the teaching arena, changes to the resource, and see how EducationCity is supporting the education community.



"Teachers have been delighted with the content of this package and most impressed with how easy it is to find appropriate learning and teaching resources and then to use them in a variety of ways."

Mark Sanderson,

Senior ICT Consultant, Herefordshire Learning and Achievement Service

Want to find out more about EducationCity?

Start a free trial for your school today and see it for yourself. Simply call us on +44 (0)1572 725080 or email trials@educationcity.com to arrange.

Website: www.educationcity.com

Email: trials@educationcity.com

